



V^ & @ æ æ Á æ ÿ æ Á

MODELS:
DBIS-09
DBIS-12
DBIS-18
DBIS-24
(Refrigerant R410A)

, ^ • ç ! } Ë |

CONTENT

1. Safety Precautions.....	1
2. Specifications	2
2.1 Unit Specifications.....	2
2.2 Operation Characteristic Curve.....	4
2.3 Capacity Variation Ratio According to Temperature.....	4
2.4 Noise Curve.....	5
3. Construction Views.....	6
3.1 Indoor Unit.....	6
4. Refrigerant System Diagram.....	7
5. Schematic Diagram.....	8
5.1 Electrical Wiring.....	8
6. Function and Control.....	9
6.1 Instructions Wired Controller Manual.....	9
6.2 Display and Installation instruction	11
6.3 Operation Instruction.....	12
6.4 Error Code.....	16
6.5 Description of Each Control Operation.....	17
7. Installation Location and Matters Needing Attention.....	20
7.1 Notices for Installation.....	20
7.2 Installation Dimension Diagram.....	21
7.3 Installation Indoor Unit	23
8. Exploded Views and Parts List.....	31
8.1 Indoor Unit.....	31
9. Troubleshooting.....	37
9.1 Error Code List.....	37
9.2 PCB Printed Diagram.....	40
9.3 Procedure of Troubleshooting.....	41
10. Removal Procedure.....	58
10.1 Removal Procedure of Indoor Unit.....	58

Summary and Features

Indoor Unit

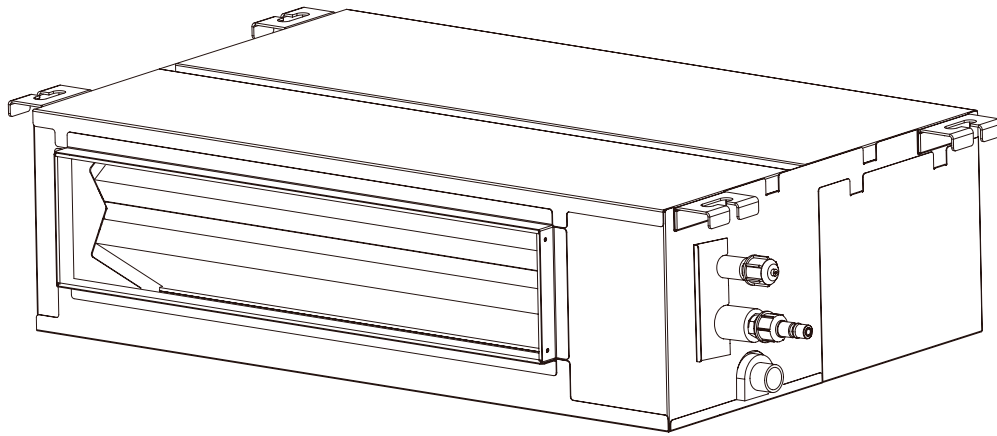

DBIS-09(I) DBIS-12(I)
DBIS-18(I) DBIS-24(I)

Wired Controller



XKRA1L

1. Safety Precautions

Installing, starting up, and servicing air conditioner can be hazardous due to system pressure, electrical components, and equipment location, etc. Only trained, qualified installers and service personnel are allowed to install, start-up, and service this equipment. Untrained personnel can perform basic maintenance functions such as cleaning coils. All other operations should be performed by trained service personnel. When handling the equipment, observe precautions in the manual and on tags, stickers, and labels attached to the equipment. Follow all safety codes. Wear safety glasses and work gloves. Keep quenching cloth and fire extinguisher nearby when brazing. Read the instructions thoroughly and follow all warnings or cautions in literature and attached to the unit. Consult local building codes and current editions of national as well as local electrical codes.

Recognize the following safety information:

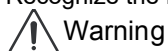

Warning

Incorrect handling could result in personal injury or death.

- ◆ Make sure the outdoor unit is installed on a stable, level surface with no accumulation of snow, leaves, or trash beside.
- ◆ Make sure the ceiling/wall is strong enough to bear the weight of the unit.
- ◆ Make sure the noise of the outdoor unit does not disturb neighbors.
- ◆ Follow all the installation instructions to minimize the risk of damage from earth quakes, typhoons or strong winds.
- ◆ Avoid contact between refrigerant and fire as it generates poisonous gas.
- ◆ Apply specified refrigerant only. Never have it mixed with any other refrigerant. Never have air remain in the refrigerant line as it may lead to rupture and other hazards.
- ◆ Make sure no refrigerant gas is leaking out when installation is completed.
- ◆ Should there be refrigerant leakage, the density of refrigerant in the air shall in no way exceed its limited value, or it may lead to explosion.
- ◆ Keep your fingers and clothing away from any moving parts.
- ◆ Clear the site after installation. Make sure no foreign objects are left in the unit.
- ◆ Always ensure effective grounding for the unit.



Caution

Incorrect handling may result in minor injury, or damage to product or property.



Warning

All electric work must be performed by a licensed technician according to local regulations and the instructions given in this manual.

Before installing, modifying, or servicing system, main electrical disconnect switch must be in the OFF position. There may be more than 1 disconnect switch. Lock out and tag switch with a suitable warning label.

Never supply power to the unit unless all wiring and tubing are completed, reconnected and checked.

This system adopts highly dangerous electrical voltage. Incorrect connection or inadequate grounding can cause personal injury or death. Stick to the wiring diagram and all the instructions when wiring.

Have the unit adequately grounded in accordance with local electrical codes.

Have all wiring connected tightly. Loose connection may lead to overheating and a possible fire hazard.

All installation or repair work shall be performed by your dealer or a specialized subcontractor as there is the risk of fire, electric shock, explosion or injury.



Caution

Never install the unit in a place where a combustible gas might leak, or it may lead to fire or explosion.

Make a proper provision against noise when the unit is installed at a telecommunication center or hospital.

Provide an electric leak breaker when it is installed in a watery place.

Never wash the unit with water.

Handle unit transportation with care. The unit should not be carried by only one person if it is more than 20kg.

Never touch the heat exchanger fins with bare hands.

Never touch the compressor or refrigerant piping without wearing glove.

Do not have the unit operate without air filter.

Should any emergency occur, stop the unit and disconnect the power immediately.

Properly insulate any tubing running inside the room to prevent the water from damaging the wall.

2. Specifications

2.1 Unit Specifications

Parameter	Unit	Value	Value
Indoor Unit Model	--	DBIS-09(I)	DBIS-12(I)
Product Code	--	KEF001N0120	KEF001N0130
Project No.	--	CK15S019.07	CK15S019.01
Detailed No.	--	KEF001.N0120MX	KEF001.N0130MX
Motor Model	--	"SF35C"	"SF45C"
Motor Manufacturer Model	--	YSK-09503504-CW53	YSK-09504504-CW54
Motor Manufacturer	--	Changzhou LEKVA Electronics Co., LTD.	Changzhou LEKVA Electronics Co., LTD.
Motor Manufacturer	--	LEKVA	LEKVA
Material code		K1680001102	K1680001202
Cooling Capacity	W	2600	3500
Cooling Capacity	Btu/h	8871.2	11942
Heating Capacity	W	2600	3500
Heating Capacity	Btu/h	8871.2	11942
Cooling Power Input	W	788.15	973.05
Heating Power Input	W	725.24	1247.45
Cooling Rated Current	A	3.42673913	4.230652174
Heating Rated Current	A	3.153217391	5.423695652
Airflow olume	m3/h	600	600
Refrigerant	--	R410A	R410A
Fan Type	--	Cross-flo	Cross-flo
Fan Diameter Length(D×L)	mm	Φ97×470	Φ97×470
Cooling Speed	r/min	1300/1220/820/665	1350/1280/770/650
Heating Speed	R/MIN	1365/1095/1005/915	1440/1140/1065/975
Rated Voltage	V	220-240	220-240
Standard Static Pressure	Pa	25	25
Fan Motor Power Output	W	35	45
Fan Motor RLA	A	0.39	0.4
Fan Motor Capacitor	μF	3	3
Number of poles	P	4	4
Authentication method	--	3C	3C
Motor Insulation Class	--	B	B
Main wire-wound resistor	Ω	134	89
Primary wire-wound resistor	Ω	139	108
Evaporator Form	--	Alumium Tube	Alumium Tube
Evaporator Pipe Diameter	mm	φ5	φ7
Evaporator Row-fin Gap	mm	0.197	0.276
Evaporator Coil Length (L×D×W)	mm	535×114.3×22.8	535×114.3×33.6
Set Temperature Range	°C	16~31	16~31
Sound Pressure Level	dB (A)	40/38/27/22	41/40/30/27
Sound Power Level	dB (A)	52/50/39/34	53/52/42/39
Dimension (W×H×D)	mm	700×200×450	700×200×450
Dimension of Carton Box (W×H×D)	mm	884×536×249	884×536×249
Dimension of Package(W×H×D)	mm	887×539×266	887×539×266
Stacked Layers	—	10	10
Net Weight	kg	16.5	17
Gross Weight	kg	19	19.5

Parameter	Unit	Value	Value
Indoor Unit Model	--	DBIS-18(I)	DBIS-24(I)
Product Code	--	KEF001N0140	KEF001N0150
Project No.	--	CK15S019.03	CK15S019.03
Detailed No.	--	KEF001.N0140MX	KEF001.N0150MX
Motor Model	--	"SF60C"	"SF70C"
Motor Manufacturer Model	--	YSK-11006004-CW55	YSK-11007504-CW56
Motor Manufacturer	--	Changzhou LEKVA Electronics Co., LTD.	Changzhou LEKVA Electronics Co., LTD.
Motor Manufacturer	--	LEKVA	LEKVA
Material code		K1680003202	K16800032
Cooling Capacity	W	5200	7000
Cooling Capacity	Btu/h	17742.4	23884
Heating Capacity	W	5200	7000
Heating Capacity	Btu/h	17742.4	23884
Cooling Power Input	W	1510.55	2425.7
Heating Power Input	W	1450.36	2054.65
Cooling Rated Current	A	6.567608696	10.54652174
Heating Rated Current	A	6.305913043	8.93326087
Airflow olume	m3/h	920	1300
Refrigerant	--	R410A	R410A
Fan Type	--	Cross-flo	Cross-flo
Fan Diameter Length(D×L)	mm	Φ112×470	Φ112×470
Cooling Speed	r/min	1340/1240/1070/940	1320/1200/1050/890
Heating Speed	R/MIN	1365/1140/1005/945	1320/1200/1050/890
Rated Voltage	V	220-240	220-240
Standard Static Pressure	Pa	25	25
Fan Motor Power Output	W	60	70
Fan Motor RLA	A	0.57	0.62
Fan Motor Capacitor	μF	3	4
Number of poles	P	4	4
Authentication method	--	3C	3C
Motor Insulation Class	--	B	B
Main wire-wound resistor	Ω	63.5	108
Primary wire-wound resistor	Ω	69.5	111
Evaporator Form	--	Alumium Tube	Alumium Tube
Evaporator Pipe Diameter	mm	φ7	φ7
Evaporator Row-fin Gap	mm	0.276	0.276
Evaporator Coil Length (L×D×W)	mm	807×114.3×40.9	807×114.3×40.9
Set Temperature Range	°C	16~31	16~31
Sound Pressure Level	dB (A)	43/41/37/33	43/41/37/33
Sound Power Level	dB (A)	55/53/49/45	55/53/49/45
Dimension (W×H×D)	mm	1000×200×450	1300×200×450
Dimension of Carton Box (W×H×D)	mm	1185×536×249	1456×467×261
Dimension of Package(W×H×D)	mm	1188×539×266	1459×470×264
Stacked Layers	—	10	10
Net Weight	kg	23	27
Gross Weight	kg	27	30

2.2 Operation Characteristic Curve

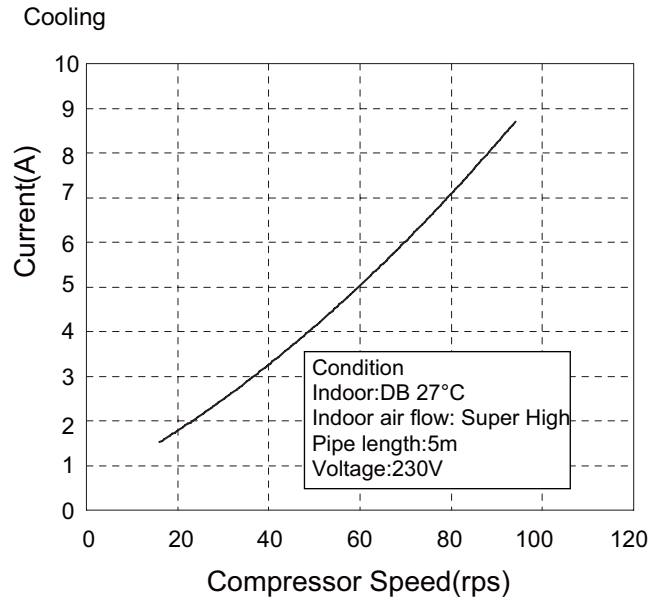

2.3 Capacity Variation Ratio According to Temperature

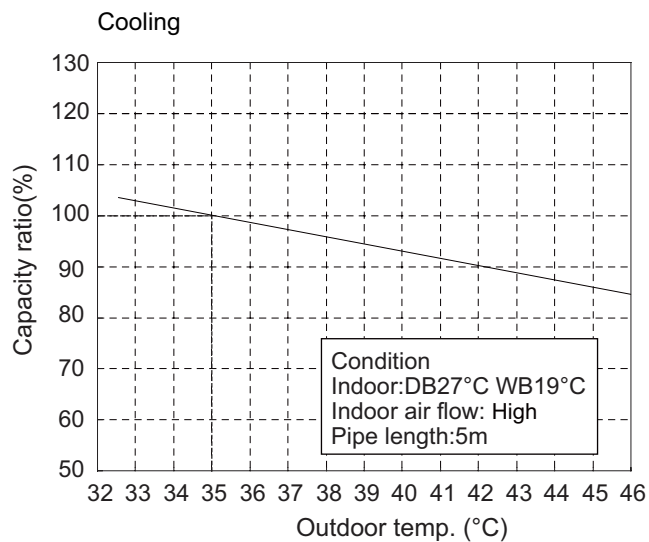
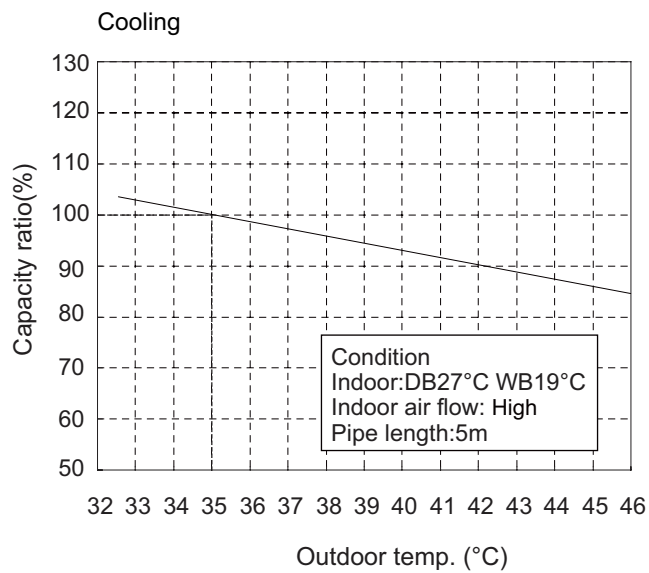

2.4 Noise Curve

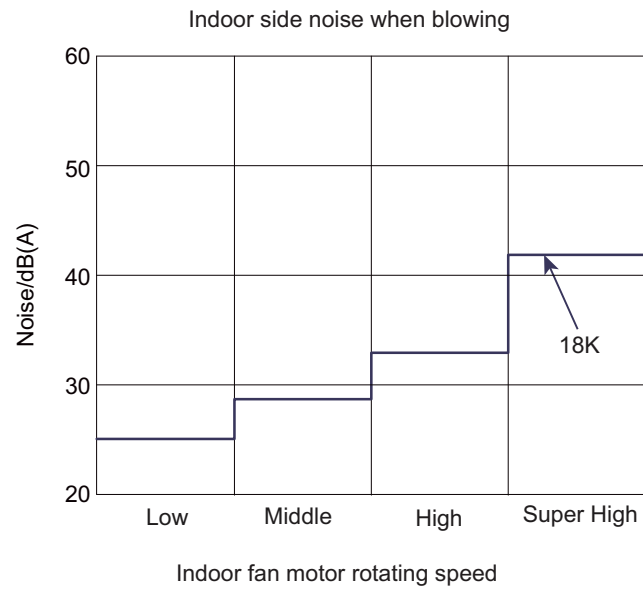
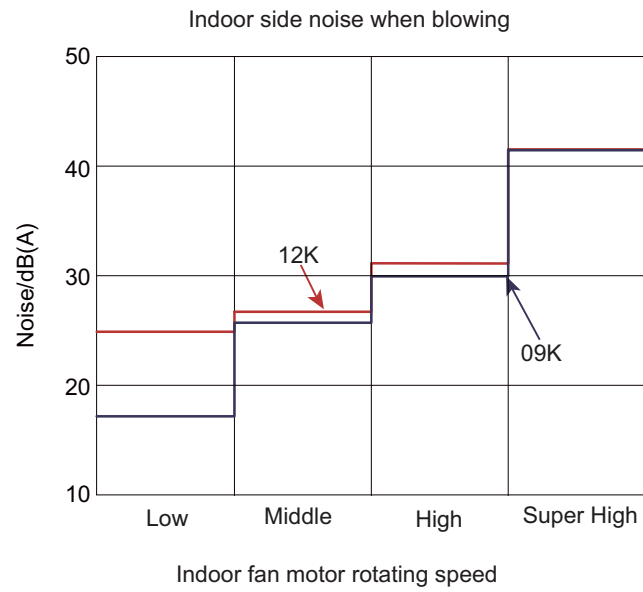

3. Construction Views

3.1 Indoor Unit

Unit:mm

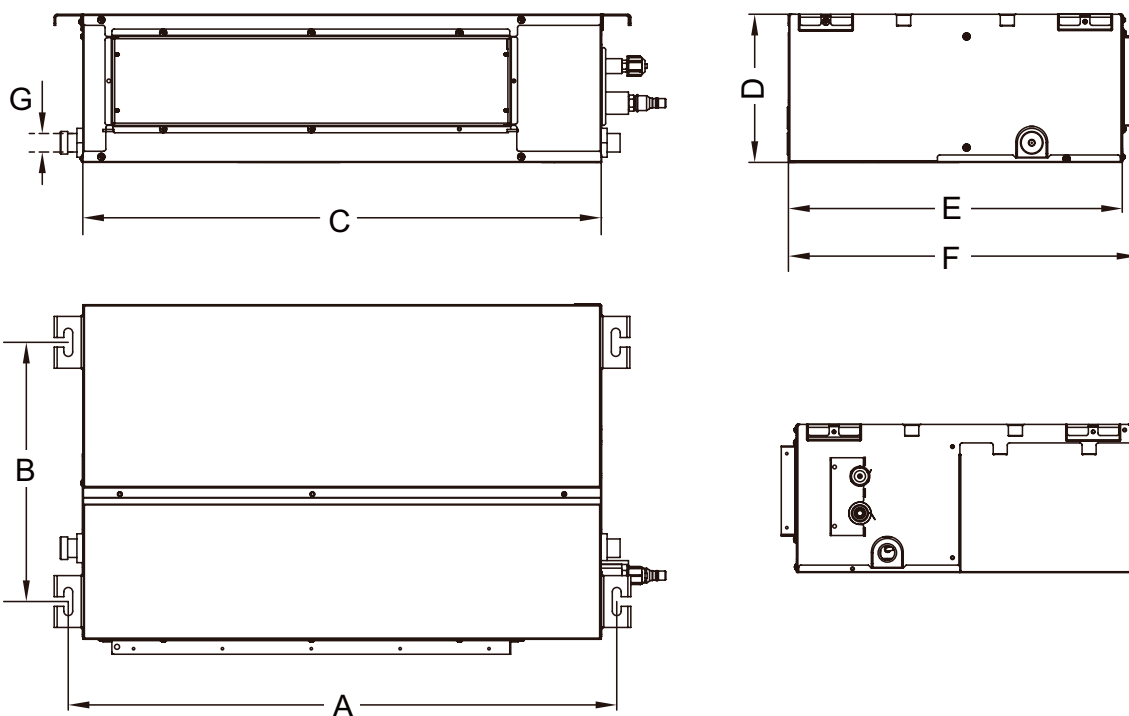

Model	A(mm)	B(mm)	C(mm)	D(mm)	E(mm)	F(mm)	G(mm)
09K/12K	740	350	700	200	450	472	26
18K	1040	350	1000	200	450	472	26
24K	1340	350	1000	200	450	472	26

4. Refrigerant System Diagram

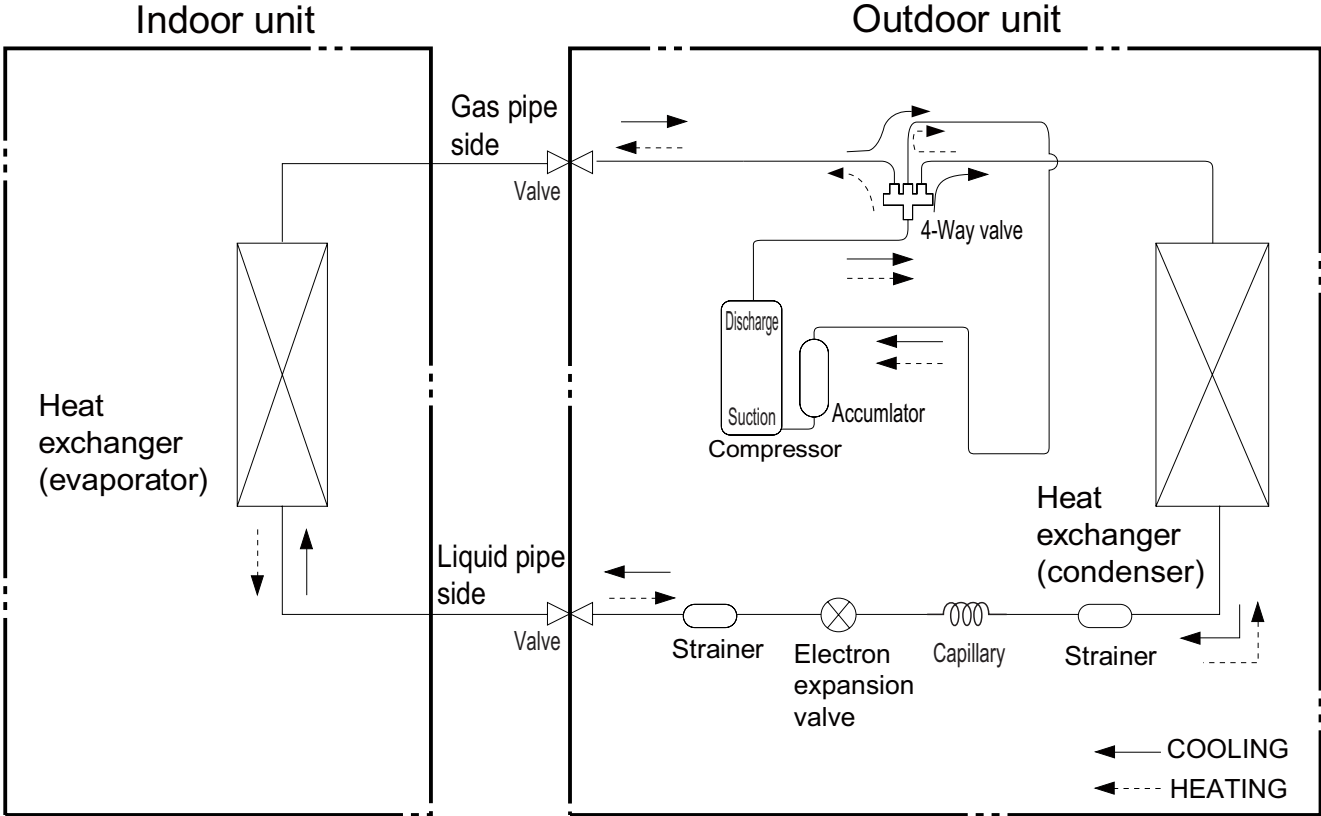

5. Schematic Diagram

5.1 Electrical Wiring

Meaning of marks

Symbol	OG	WH	YE	RD	YEGN	BN	BU	BK	VT
Color symbol	ORANGE	WHITE	YELLOW	RED	YELLOW GREEN	BROWN	BLUE	BLACK	VIOLET
Symbol	COMP		CT1,2		4V	XT			
Parts name	COMPRESSOR		OVERLOAD		4-WAY VALVE	TERMINAL BLOCK			PROTECTIVE EARTH

Indoor Unit

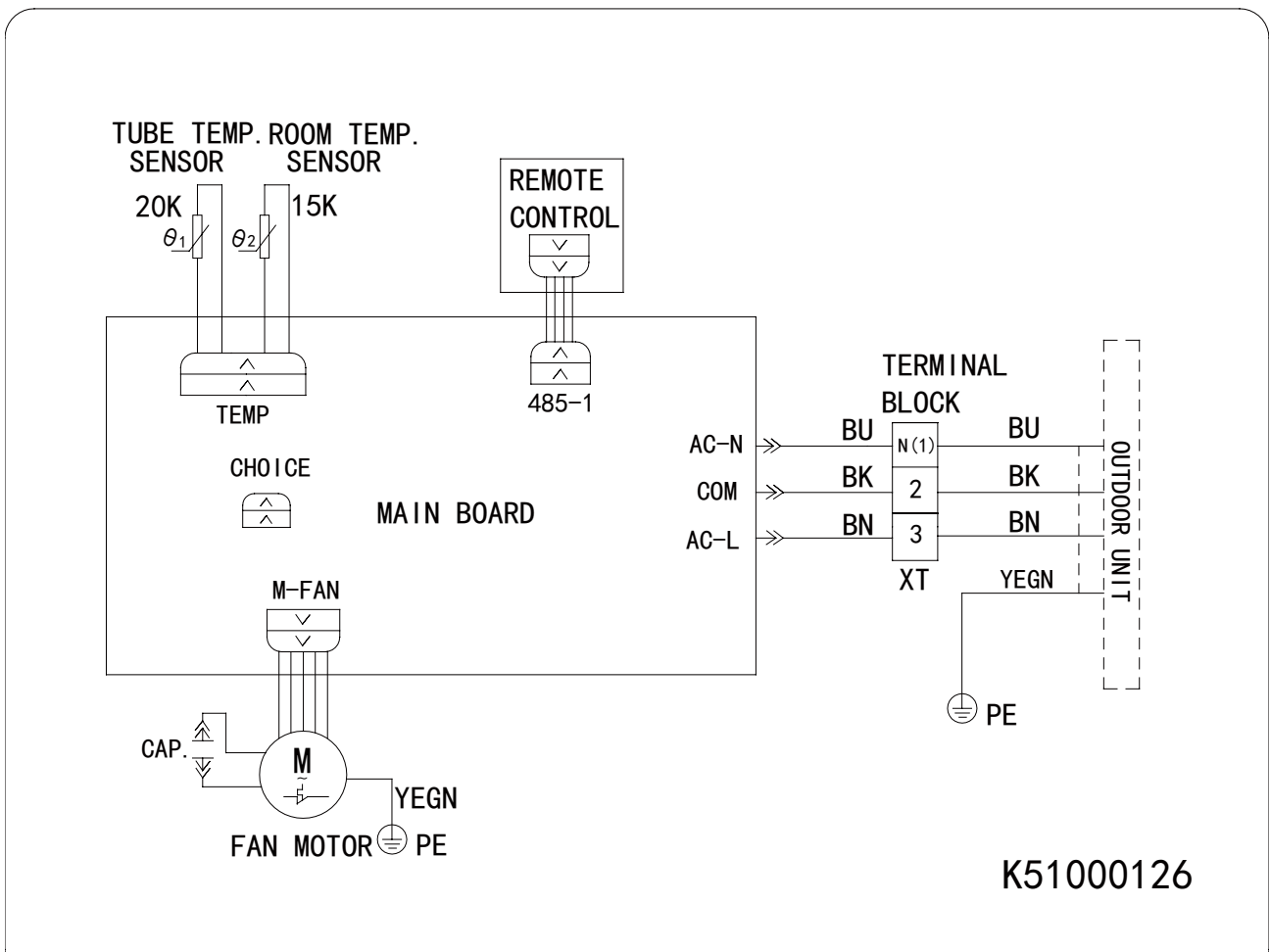

These circuit diagrams are subject to change without notice, please refer to the one supplied with the unit.

6. Function and Control

6.1 Instructions Wired Controller Manual

User Instructions

Please carefully read this manual before installation and use of this product.

- Do not install or remove the wired controller by yourself. If necessary, please contact the aftersales serviceman.
- Do not install the wired controller in the humid area or under direct sunlight.
- Do not beat, toss, or frequently assemble/disassemble the wired controller.
- Do not operate the wired controller with wet hands.
- This wired controller is applicable to various kinds of air conditioners, while some specific functions unavailable to the duct type air conditioners will not be covered in this manual.

6.1.1 Installation and Disassembly

1. Installation Place and Installation Requirements

- Do not install the wired controller in the humid area or under direct sunlight.
- Do not install the wired controller close to the high-temperature object or place where is easy to splash on the wired controller.
- Do not install the wired controller directly opposite to the window so as to avoid improper operation caused by the interference of the neighbor's same model wired controller.
- Please cut off the power supply of wires embedded in the wall. No operation is allowed with electricity.
- To avoid abnormal operation caused by electromagnetic interference or other causes, please take notice of the following statements during wiring.
 - 1). Be sure the communication line is wired into the correct port, otherwise it would lead to communication fault.
 - 2). The communication line (wired controller) and power line must be separated with the minimal distance of 20 cm, otherwise it would lead to communication fault.
 - 3). If the air conditioner is installed where is easy to suffer electromagnetic interference, the communication line of the wired controller must be shielded twisted pair.

6.1.2 Installation of the Signal Wire

1. Open the indoor unit electric box cover.
2. Make the signal line go through the rubber band
3. Insert the signal wire port in the 4-seat needle which on the indoor unit circuit board.
4. Tightly fix the signal wire with wire ties.

Notice:

The communication distance between main board and wired controller can reach 20m. (The recommended length is 8m)

6.1.3 Installation of Wired Controller

The simple installation step of wired controller is as shown on the figure, please notice below issues:

- Pull out the 4 core twisted pair wire from the mounting hole and pass this line through the oblong hole located at the bottom of the wired controller.
- Use M4×25 screws to fix the base plate together with installation hole of the wall.
- Insert the through signal wire in the slot on the wired controller, also lock the wired controller panel and base plate together.
- Then use ST2.2×4.5 screw to fixed the wired controller panel and base plate together.

Wired controller installation steps:

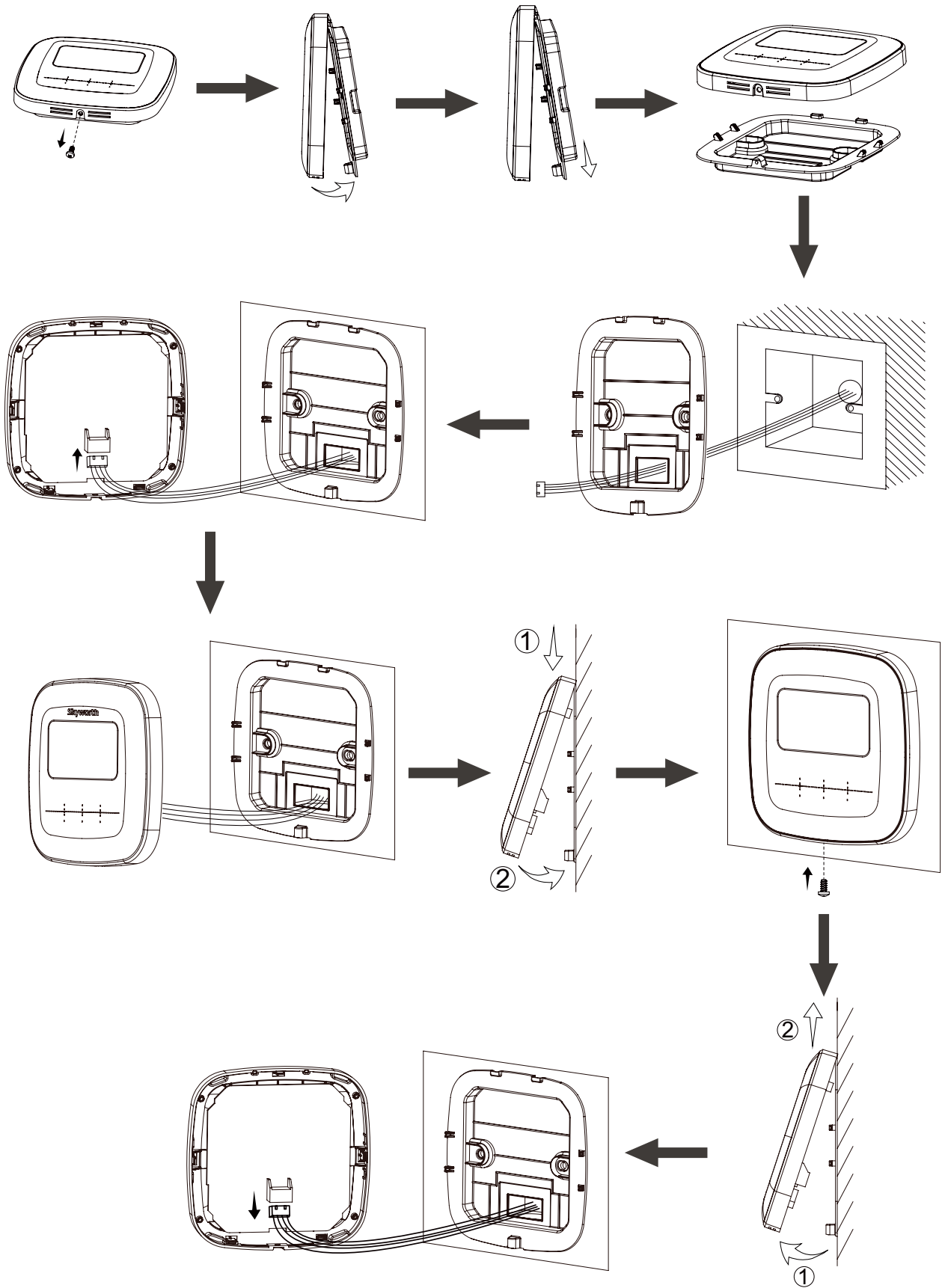

6.2 Display and Installation instruction

Liquid crystal display:

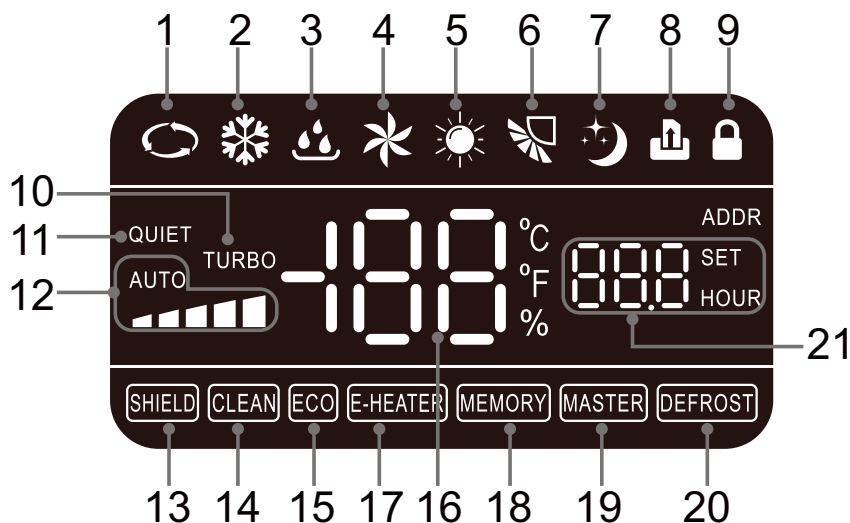

No.	Icon Name	Icon Instruction
1	AUTO	Operating in AUTO mode
2	COOLING	Operating in COOLING mode
3	DRY	Operating in DRY mode
4	FAN	Operating in FAN mode
5	HEATING	Operating in HEATING mode
6	SWING	SWING function status
7	SLEEP	SLEEP function status
8	ACCESS CONTROL	Plug-in/out card status
9	LOCK	Keyboard lock status
10	TURBO	TURBO function status
11	QUIET	QUIET function status
12	FAN SPEED	Current setting fan speed
13	SHIELD	Shield status
14	CLEAN	CLEAN function status
15	ECO	ECO function status
16	TEMP.	Ambient temp. / setting temp.
17	E-HEATER	E-HEATER function status
18	MEMORY	MEMORY function status
19	MASTER	Indicate that the indoor unit is master
20	DEFROST	DEFROST function status
21	TIMER	TIMER status

Bottoms:

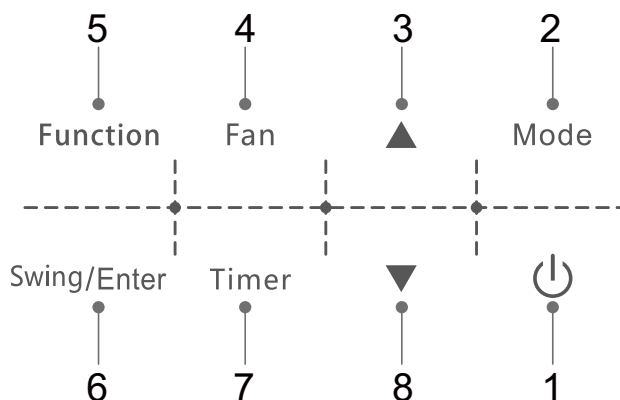

No.	Button Name	Button Instruction
1	Switch	Turn on/off unit
2	Mode	"Select the operating mode : AUTO, COOLING, DRY, FAN, HEATING"
3	▲	"1. Setting operating temp., range: 16-31°C (61°F-88°F) 2. Setting timer time, range: 0.5-24 hour"
8	▼	
4	Fan	Adjust fan speed
5	Function	Select CLEAN, ECO, SLEEP, TURBO, QUIET, etc. fuctions.
6	Swing/Enter	"1. Turn on/off Swing function. 2. Turn on/off function"
7	Timer	Setting timer on/off

6.3 Operation Instruction

Lock Function

In the on/off-state, press "▲" and "▼" buttons at the same time for 5s till the wired controller enters the lock state. In this case, the LED display "🔒". After that, repress these two buttons at the same time for 5s to quit the lock state. Notice:

In the lock state, if malfunction occur, all the buttons will be shield besides ON/OFF button.

The Switch of Centigrade and Fahrenheit

In On/Off-state, press "Mode" and "▼" button for 5s to switch between Centigrade and Fahrenheit.

Checking the Temp. of Temp. Sensor

In On/Off-state, press "Mode" and "Fan" button can show the detected temp. of indoor temp. sensor for 5s, then exit automatically.

Defrost Function

In Heating mode, when the condition meets the standard that the outdoor unit control system can turn on the defrost function, the units will defrost automatically, "DEFROST" icon appear.

On/Off

Press the "🔌" button to turn on or off the unit.

Mode Setting

In on-state, press the "Mode" button to switch the operation modes as the sequence shown in below:

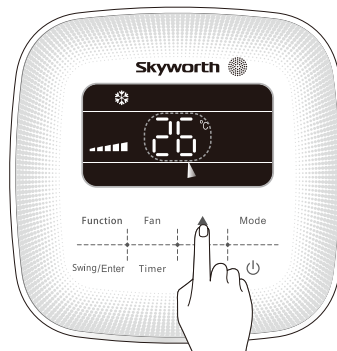
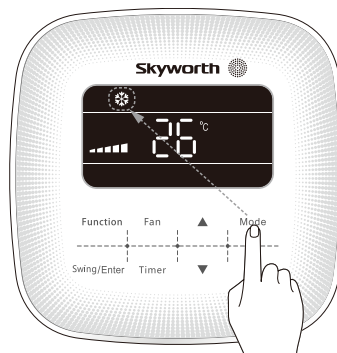

Temperature Setting

Press "▲" or "▼" button to increase or decrease setting temperature in on-state of the unit. If press either of them continuously, temperature will be changed rapidly. Temperature setting range is 16°C~31°C (61°F-88°F). Notice:

In Auto mode, the setting temperature is un-adjustable.

Fan Speed Setting

Press "Fan" button, fan speed of indoor unit will change as the sequence below:



Notice:

- After installation completed, wired controller will detect the unit type automatically. Different types may have different ways of fan speed display, it can be divided into the 2 kinds above.
- In DRY mode, the fan speed is default to low fan speed and can not be adjusted.
- When set the AUTO mode, the indoor fan speed will be changed according to the indoor ambient temp., the fan speed strip is not displayed.

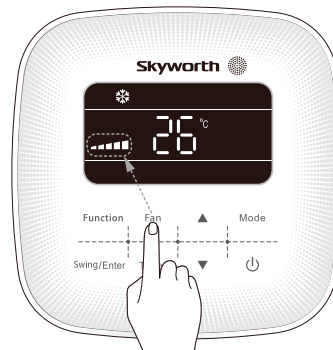

Swing Setting

In on-state, each time you press the: "Swing/Enter" button, the swing function will be adjusted as below sequence:

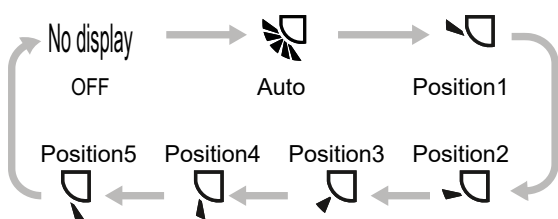

Notice:

When switch from "Off" to "Auto", if press "Swing/Enter" button after 2s will switch to "Off" directly; If press "Swing/Enter" button in 2s, the swing function will change as the sequence above.

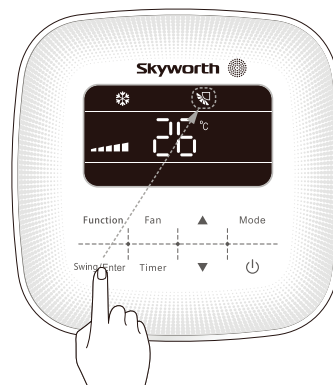

Timer Setting

In on-state, press "Timer" button to set turn off time; in off-state, press "Timer" button to set turn on time. Timer range: 0.5-24h.

Notice: The min gap of time display is 0.5h, less than 0.5h will display 0.5h.

- Timer Setting: Press "Timer" button, "SET" icon blinking, "HOUR" icon displayed, then press "▲" / "▼" to adjust the time, after that, press the "Timer" button again to make a confirmation ("SET" disappeared), setting complete.
- Cancel Timer Setting: After Timer is set, press "Timer" button, "HOUR" icon and timer time disappear, setting canceled.

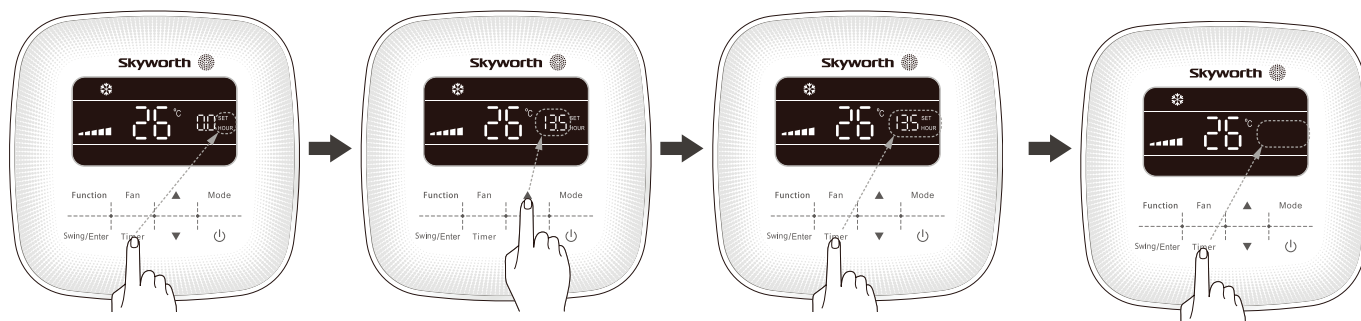

Press "Timer" button, "SET" icon blinking, "Hour" icon displayed

Press "▲" / "▼" to adjust the time

Press the "Timer" button to complete the setting

Press "Timer" button cancel the timer setting

Turbo Function Setting

TURBO function: The unit at the highest fan speed can realize quick cooling or heating so that room temperature can quickly approach the setting temperature.

Press "Function" button switch to the Turbo function, "TURBO" icon blinking, press "Swing/Enter" button to turn on/off the function.

Notice:

- When turn on Turbo function, the fan speed strip will not change.
- Switch to other mode and adjust the fan speed will both exit the Turbo function automatically.
- Power on/off will turn off the Turbo function.
- Can not turn on "Turbo" and "Quiet" function in the same time.
- There has no Turbo function in Dry/Auto mode.

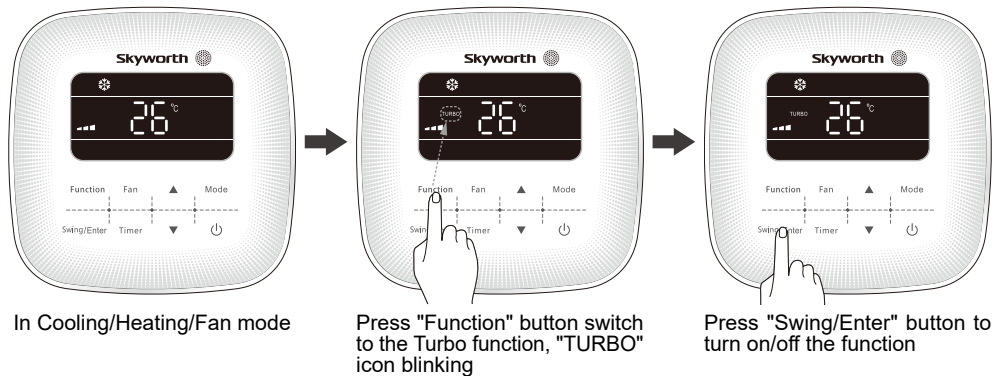

Sleep Function Setting

In Cooling/Heating/Dry mode, press "Function" button switch to the Sleep function, "☾" icon blinking, press "Swing/Enter" button to turn on/off the function.

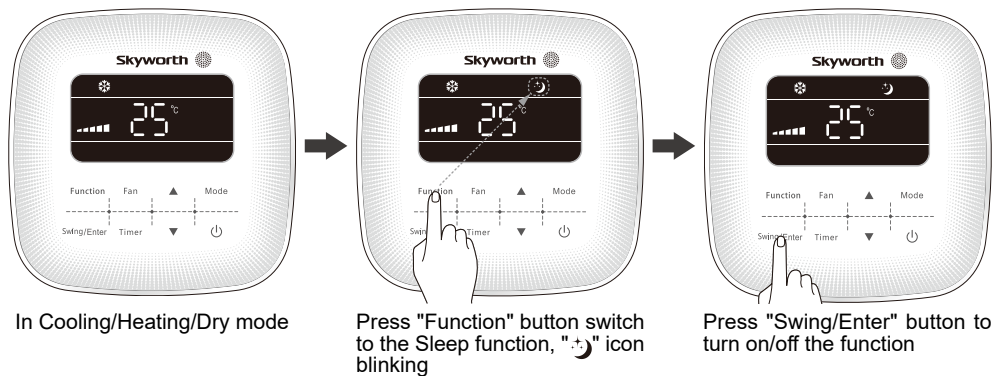

Quiet Function Setting

Press "Function" button switch to the Quiet function, "QUIET" icon blinking, press "Swing/Enter" button to turn on/off the function.

Notice:

- When turn on Quiet function, the fan speed strip will not change.
- Switch to other mode and adjust the fan speed will both exit the Quiet function automatically.
- Power on/off will turn off the Quiet function.
- Can not turn on "Turbo" and "Quiet" function in the same time.
- There has no Quiet function in Dry mode.

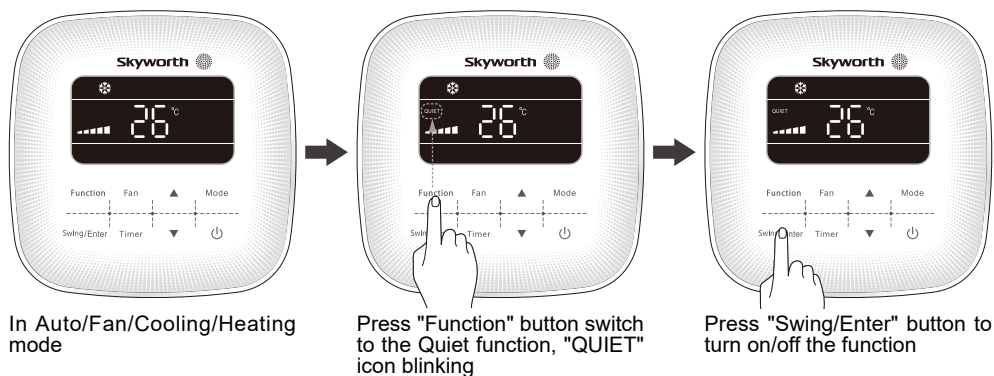

Clean Function Setting

Clean function: After the unit is turned off, water in evaporator of indoor unit will be automatically evaporated to avoid mildew. In Cooling or Dry mode, press "Function" button to switch to Clean function, "CLEAN" icon blinking, press "Swing/Enter" button to turn on/off this function

Notice:

- In Auto, Fan, heating mode, Clean function is not available.
- Clean Function can be canceled in off-state.

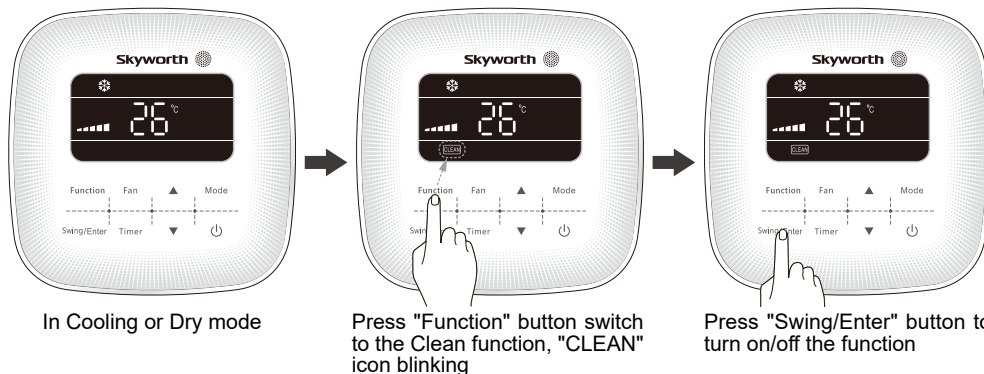

ECO Function Setting

ECO function can make the air conditioner runs in a smaller temperature range by setting limited value of setting temperature in the Cooling or heating mode to achieve energy saving.

In Cooling(Heating) mode, press "Function" button to switch to ECO limited temperature setting function, "ECO" and "❄️" ("☀️") icon blinking, press "▲" / "▼" button to set cooling(heating) limited setting temperature, then press "Swing/Enter" button to turn on/off this function.

The initial min. limited cooling setting temperature is 26°C(79°F), the initial heating max. limited heating setting temperature is 22°C(72°F).

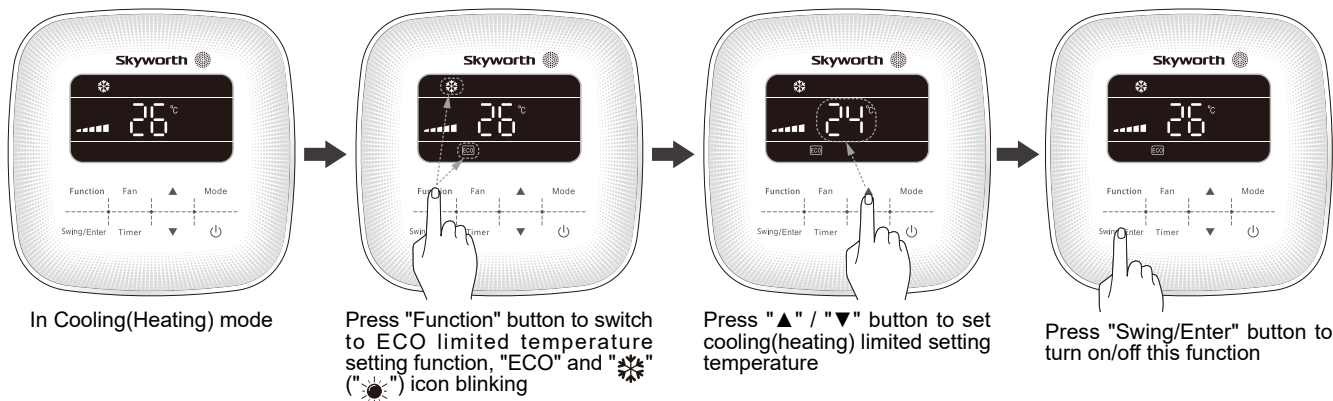

6.4 Error Code

When error happens to the unit, the error code will be shown on the wired controller. When multiple errors simultaneously happen, the error codes will circularly show up.

When error occurs, please immediately shut down the unit and contact service center.

- If show other code, please turn off and contact the service center.
- If show "CL", please turn off and clean the filter(please cut off power before take out filter).

Finish clean and well install the filter, please turn on , then the code will disappear.



Error Code	Name
CL	Filter clean remind
E0	High exhaust temp. protection
E1	Overcapacity protection
E2	Compressor overload protection
E3	Anti-frost protection
E4	System high pressure protection
E5	System low pressure protection
E6	Lack refrigerant/ valve stop protection
HE	Auxiliary heat adhesion protection
L7	The communication between indoor unit and wired controller fault
U0	Indoor temp. sensor open/short circuit
U2	Outdoor temp. sensor open/short circuit
U9	Wired controller temp. sensor fault
dF	Defrost or heating oil return
L3	Indoor unit report outdoor unit fault
L9	Water full protection

6.5 Description of Each Control Operation

1、 Control Mode

1. Auto 2. Cool 3. Dry 4. Fan 5. Heating

2、 Control target

Indoor fan(Quiet、 speed 1、 speed 2、 speed 3、 speed 4、 speed 5、 Turbo), left and right louver, up and down louver, buzzer, display, outdoor electric heater(option), outdoor power, healthy(option).

3、 Basis control function

(3.1)、 Cooling mode

(1) Setting Temp 16~31 degree(61F~ 88F),the indoor fan and louver run as the original mode.

(2) The indoor will run as original mode if the outdoor does not work,and the indoor will show error code.

(3.2)、 Dry mode

(1) In this mode, swing will work as setting, indoor fan running in low speed, the temperature setting range is 16~ 31°C (61F~88F).

(2) The indoor will run as original mode if the outdoor does not work,and the indoor will show error code.

(3.3)、 Fan Mode

(1) Setting Temp 16~31 degree(61F~88F),the indoor fan and louver run as the original mode.

(2) The indoor will run as original mode if the outdoor does not work,and the indoor will show error code.

(3.4)、 Heating mode

(1) Setting temperature range 16-31 degree(61F~88F).

(2) It will in anti-cold air first when unit run in heating mode,and then heating.It will blow hot air after unit is off.

(3)The electrical heating belt will open(optional) when the temperature is so low after the fan motor start.

(4) Indoor power light blink and then indoor fan stop after unit entering defrost mode.

(5) Indoor blow hot air 1 minute if outdoor is malfunction.

(6) Indoor blow hot air 10 minutes after turn off unit when indoor fan is running.

(3.5)、 Auto mode

(1) When environment temperature is equal or above 26 degree(79 °F),and setting the cooling mode,the setting temperature will reach 25 degree(79 °F).

(2) When the environment temperature T is equal or below 19 degree(69 °F) plus additional temperature,it will run in heating mode,and the setting temperature reach 20 degree(68 °F) at that time.

(3) When (19 degree +additional temperature,) < environment temperature < 26 degree. It will run in airfan mode if it is the first time entering auto mode. It will run in original mode if it change from cooling and heating mode. (If original mode is dehumidify, it will be auto mode.)

If all mode is starting and it needs 30 seconds to change into auto mode by press Temp under auto mode.

4、 Other Function

4.1、 Timer Setting

In on-state, press "Timer" button to set turn off time; in off-state, press "Timer" button to set turn on time.

(1) Timer Setting: Press "Timer" button, "SET" icon is blinking, "HOUR" icon displayed, then press "▲" / "▼" to adjust the time, after that, press the "Timer" button again to make a confirmation ("SET" disappeared), setting complete.

(2) Timer running: "SET" icon isn't blinking, "HOUR" icon displayed, and the timer will show the reducing time and until to 0 and then timer will disappear. It will change to on/off status.

(3) Cancel Timer Setting:

After Timer is set, press "Timer" button, "HOUR" icon and timer time disappear, setting canceled.

4.2、 Swing control

(1). swing rating: press the: "Swing/Enter" button, the swing function will be adjusted as below sequence "off, auto swing, Position 1, Position 2, Position 3, Position 4, Position 5, and followed by recycling. The swing function will be closed when the unit restarts.

(2). Swing: press the: "Swing/Enter" button and set "off and auto swing".

4.3、 Dry function

Under cool and dry mode, Press "function" button, it will change into dry function and then Dry is blinking. Please press "swing/enter" button to open and close dry function.

Fan motor of indoor unit will be running 3 mins with mid-speed and other parts will off when close the indoor unit. After 3 mins the fan motor will off and indoor unit will off.

4.4、 TURBO function:

Press "Function" button switch to the Turbo function, "TURBO" icon blinking, press "Swing/Enter" button to turn on/off the function.

4.5、 Quiet Function

Press "Function" button switch to the Quiet function, "QUIET" icon blinking, press "Swing/Enter" button to turn on/off the function. It does not have Quiet function in Dry mode.

4.6、 ECO function

In Cooling(Heating) mode, press "Function" button to switch to ECO limited temperature setting function, "ECO" and "Dry"("heating ") icon blinking, press "▲" / "▼" button to set cooling(heating) limited setting temperature, then press "Swing/Enter" button to turn on/off this function. The initial min. limited cooling setting temperature is **26°C(79°F)**, the initial heating max. limited heating setting temperature is **22°C(72°F)**.

4.7、 Sleep Function

In Cooling/Heating/Dry mode, press "Function" button switch to the Sleep function, "sleep " icon blinking, press "Swing/Enter" button to turn on/off the function.

It does not have Quiet function in auto/fan mode.

4.8、 Switching °C and °F

Press "mode " and "▼", and then it will be switch °C and °F .

4.9、 Check the degree of temperatures by temperatures sensors

In the on/off-state, press "fan" and "mode" and it will show the value of temperatures by temperatures sensors of indoor units, exit after 5 seconds.

4.10、 Lock Function

In the on/off-state, press "▲" and "▼" buttons at the same time for 5s till the wired controller enters the lock state. In this case, the LED display "🔒". After that, repress these two buttons at the same time for 5s to quit the lock state. Or it will display "🔒" when pressing other button.

Notice:

In the lock state, if malfunction occur, all the buttons will be shield besides ON/OFF button.

5、 Debugged function for after-sales service

In the on/off-state, Press "function" and "▼" for checking parameters of after-sales services and setting system, it will show 00 in temperature area and address codes in timer area.

Press "function" change 00 to 34 in temperature area , Press "▲" or "▼" to set parameters in timer area, Press "Swing/Enter" to confirm.

Press "Function" and "▼" to remember the set and exit functions for checking parameters of after-sales services.

Note: if the units open this function and Collecting freon function , Trail running function and force defrosting function will be not work .

1、 Collecting freon 31

Cool within 5mins, After checking parameters of after-sales services and setting system, Press "function" change to 31 showed in temperature area , Press "▲" and "▼" change to ON/OFF, Press "Swing/Enter" to confirm.

The indoor fan motor will be running at a high speed and the wire controller will show the code of b2 in temperature area.

If the unit receive the any signal from indoor units or off signal from indoor unit, it will be exit the collecting freon function and the indoor unit will be closed.

2、 Trail running function 32

In cooling mode , After checking parameters of after-sales services and setting system, Press "function" change to 31 showed in temperature area , Press "▲" and "▼" change to ON/OFF, Press "Swing/Enter" to confirm. The wire controllers will show Code "LL" in temperature area, If the unit receive the any signal from indoor units or off signal from indoor unit, it will be exit the Trail running function and the indoor unit will be closed.

3、 Force defrosting 34

In heating mode , After checking parameters of after-sales services and setting system, Press "function" change to 34 showed in temperature area , Press "▲" and "▼" change to ON/OFF, Press "Swing/Enter" to confirm. The wire controllers will show Code "dF" in temperature area and the cion of heating and defrosting will show at the same time. when wire controller receive the signal from outdoor units and it will exit the force defrosting function.

4. Ambient temperature sensor set 14

In the on/off-state, after checking parameters of after-sales services and setting system, Press "function" change to 14 showed in temperature area and change the Ambient temperature sensor set.

1, Ambient temperature of indoor units is return air Ambient temperature(01 will be showed in timer area). It needs temperature compensation in heating mode.

The Ambient temperature will be equal to ambient temperature of samples subtract 3°C.

2, Ambient temperature of indoor unit is the temperature around the wire controller.(02 will be showed in timer area)

3, Cooling, Dry, Fanmode will select the return air ambient temperature and Auto mode will select temperature around the wire controller.

5 Memory Function 13

1. At the state of turning on the units by wired controller, long press the "Function" and "+" button at the same time, then you can check the parameter of system. The temperature area will show "00", the time setting area will show the address code.

2. Press the "Function" 13 times to set the temperature area to show "13" from "00".

Then press "▲" or "▼" to make the time setting area showing "01". ("01"-Memory off, "02"-Memory on)

3. Finally, press the "Swing" button to enter.

7. Installation Location and Matters Needing Attention

7.1 Notices for Installation

The installation of the unit must comply with the national and local safety regulations. The installation quality directly affects the normal use, so the user should not carry out the installation personally, instead, the installation and debugging should be done by technician according to this manual. Only after that, can the unit be energized.

How to select the installation location for the indoor unit

1. Where there is no direct sunlight.
2. Where the top hanger, ceiling and the building structure are strong enough to withstand the weight of the unit.
3. Where the drain pipe can be easily connected to outside.
4. Where the flow of the air inlet/outlet is not blocked
5. Where the refrigerant pipe of the indoor unit can be easily led to outside.
6. Where there is no inflammabl 、 explosive substances or their leakage.
7. Where there is no corrosive gas、 heavy dust、 salt mist、 smog or moisture.

CAUTION!

The unit installed in the following places is likely to run abnormally .if unavoidable, please contact the professional personnel at the SKYWORTH appointed service center.

- Where is full of oil.
- Alkaline soil off the sea.
- Where there is sulfur gas (like sulfur hot spring).
- Where there are devices with high frequency (like wireless devices, electric welding devices, or medical equipment).
- Special circumstances.

Electric wiring

1. The installation must be done in accordance with the national wiring regulations.
2. Only the power cord with the rated voltage and exclusive circuit for the air conditioning can be used.
3. Do not pull power cord by force.
4. The electric installation should be carried out by the professional personnel as instructed by the local laws, regulations and also this manual.
5. The diameter of the power cord should be large enough and once it is damaged It must be replaced by dedicated one.
6. The earthing should be reliable and the earth wire should be connected to the dedicated device of the building by the professional personnel. Besides, the air switch coupled with the leakage current protection switch must be equipped, which is of enough capacity and of both magnetic and thermal tripping functions in case of the short circuit and overload.

Earthing Requirements

1. The air conditioner is classified into the class I appliances, so its earthing must be reliable.
2. The yellow-green line of the air conditioner is the earth line and can not be used for other purpose, cut off or fixed by the tapping screw, otherwise it would cause the hazard of the electric shock.
3. The reliable earth terminal should be provided and the earth wire cannot be connected to any of the following places.
 - (1) Running water pipe
 - (2) Coal gas pipe
 - (3) sewage pipe
 - (4) other places where the professional personnel think unreliable

7.2 Installation Dimension Diagram

• Indoor

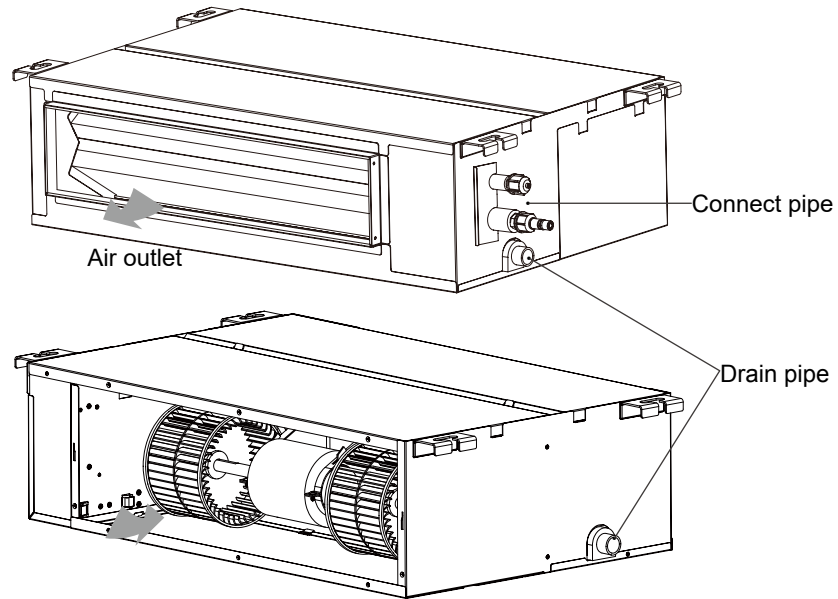

• Wired Controller











NOTE:

- The connection pipe and duct for this unit should be prepared by the user.
- The unit is standard equipped with rectangular duct.

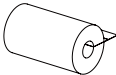
Accessories for installation

The standard accessory parts listed below are furnished and should be used as required.

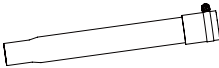
Table 1

	Name	Appearance	Q'ty	Usage
Indoor Unit	Wired Controller		1	To control the indoor unit
	Screw		2	To install the wired controller
	Insulation		2	To insulate the drain pipe
	Insulation		2	To insulate the gas and liquid pipe
	Corrugated pipe		2	Only for 24 unit
	Nut		1 or 2	Only one for 24 unit
	Nut		4	To install the indoor unit
	Drain pipe		1	
	Fastener		6	To fasten the sponge
	Others	Instructions、bar code		

7.3 Installation Indoor Unit

Dimension Requirements on the Installation Space of the Indoor Unit

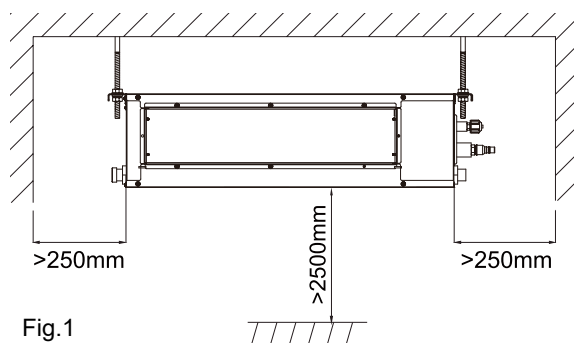

Fig.1

Installation of the Indoor Unit

a. Requirements on the Installation Location

1. Ensure the hanger is strong enough to withstand the weight of the unit.
2. The drainage of the drain pipe is easy.
3. No obstacle is in the inlet/outlet and the air circulation in good condition.
4. Ensure the installation space shown in Fig.1 is left for the access to maintenance.
5. It should be far away from where there is heat source, leakage of inflammable, explosive substances, or smog
6. It is the ceiling type unit (concealed in the ceiling)
7. The power cords and connection lines of the indoor and outdoor units must be at least 1m away from the TV set or radio to avoid the image interference and noise (even if 1m is kept, the noise may be produced due to the strong electric wave)

b. Installation of the indoor unit

1. Drilling Holes for Bolts and Installing the Bolts

Using the installation template, drill holes for bolts (four holes). (Fig.2)

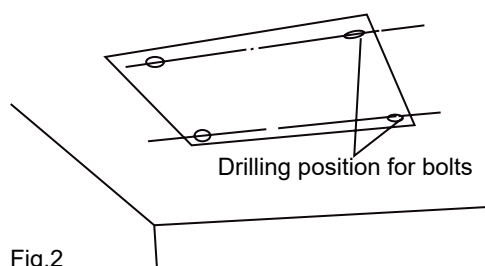

Fig.2

2. Installing the Suspension Bolts

- (1) Install the bolts to the ceiling at a place strong enough to hang the unit. Mark the bolt positions from the installation template. With a concrete drill, drill for 12.7mm (1/2") diameter holes. (Fig. 3)
- (2) Insert the anchor bolts into the drilled holes, and drive the pins completely into the anchorbolts with a hammer. (Fig. 4)
- (3) Install the hanger to the unit.
- (4) Pass the unit hangers over the bolts installed to the ceiling and install the unit with the special nut. (Fig.5)

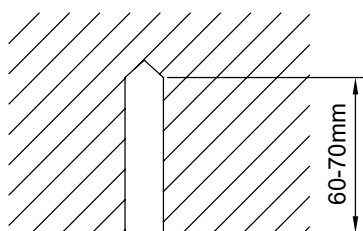

Fig.3

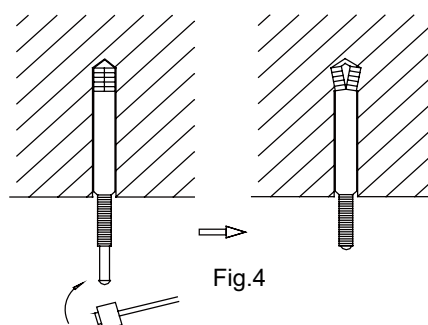

Fig.4

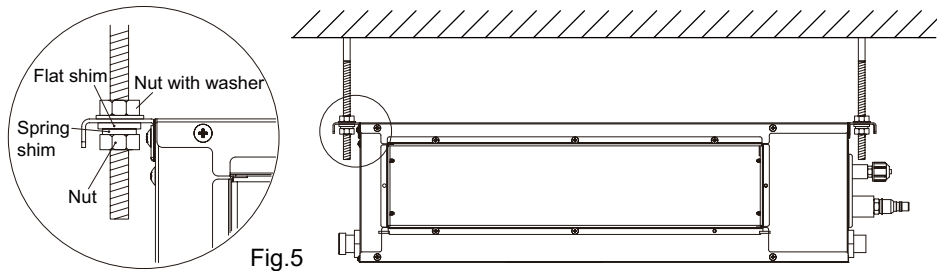

Fig.5

CAUTION!

- Prior to the installation, please make a good preparation for all piping (refrigerant pipe, drain pipe) and wiring (wires of the wired controller, wires between the indoor and outdoor unit) of the indoor unit to make the further installation much easy.
- If there is an opening in the ceiling, it is better to reinforce it to keep it flat and prevent it vibrating. Consult the user and builder for more details.
- If the strength of the ceiling is not strong enough, a beam made of angle iron can be used and then fix the unit on it.
- If the indoor unit is not installed in the air conditioning area, please use sponge around the unit to prevent condensing. The thickness of the sponge depends on the actual installation environment.

Installation of the Connection Pipe

a. Flare Processing

1. Cut the connection pipe with the pipe cutter and remove the burrs.
2. Hold the pipe downward to prevent cuttings from entering the pipe.
3. Remove the flare nuts at the stop valve of the outdoor unit and inside the accessory bag of the indoor unit, then insert them to the connection pipe, after that, flare the connection pipe with a flaring tool.
4. Check if the flare part is spread evenly and there are no cracks (see Fig.6)

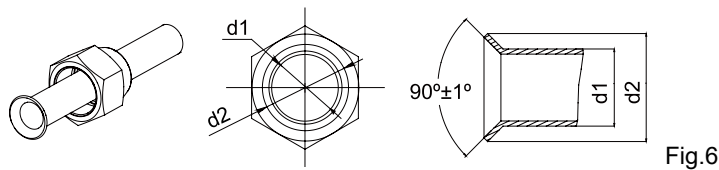
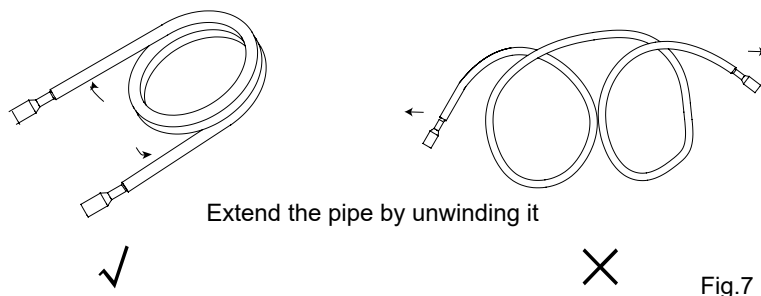

Fig.6

b. Bending Pipes

1. The pipes are shaped by your hands. Be careful not to collapse them.



Extend the pipe by unwinding it

Fig.7

2. Do not bend the pipes in an angle more than 90°.
3. When pipes are repeatedly bent or stretched, the material will harden, making it difficult to bend or stretch them any more. Do not bend or stretch the pipes more than three times.
4. When bending the pipe, do not bend it as is. The pipe will be collapsed. In this case, cut the heat insulating pipe with a sharp cutter as shown in Fig.8, and bend it after exposing the pipe. After bending the pipe as you want, be sure to put the heat insulating pipe back on the pipe, and secure it with tape.

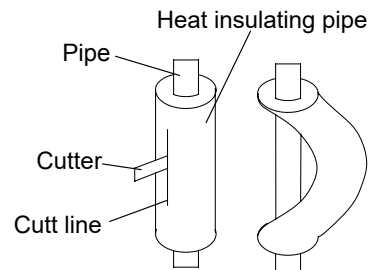

Fig.8

CAUTION!

- To prevent breaking of the pipe, avoid sharp bends. Bend the pipe with a radius of curvature of 150 mm or over.
- If the pipe is bent repeatedly at the same place, it will break.

c. Connecting the Pipe at the Indoor Unit Side

Detach the caps and plugs from the pipes.

CAUTION!

- Be sure to apply the pipe against the port on the indoor unit correctly. If the centering is improper, the flare nut cannot be tightened smoothly. If the flare nut is forced to turn, the threads will be damaged
- Do not remove the flare nut until the connection pipe is to be connected so as to prevent dust and impurities from coming into the pipe system.

Centering the pipe against port on the indoor unit, turn the flare nut with your hand

CAUTION!

Hold the torque wrench at its grip, keeping it in the right angle with the pipe as shown in Fig. 9, in order to tighten the flare nut correctly.

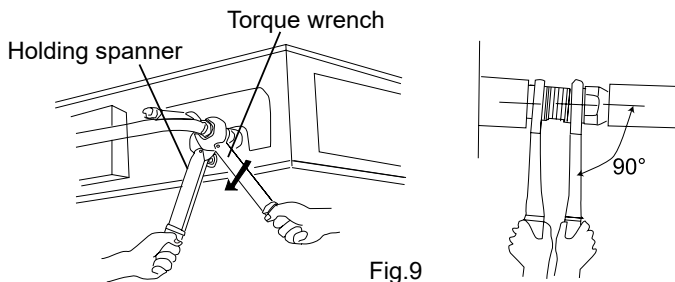

Fig.9

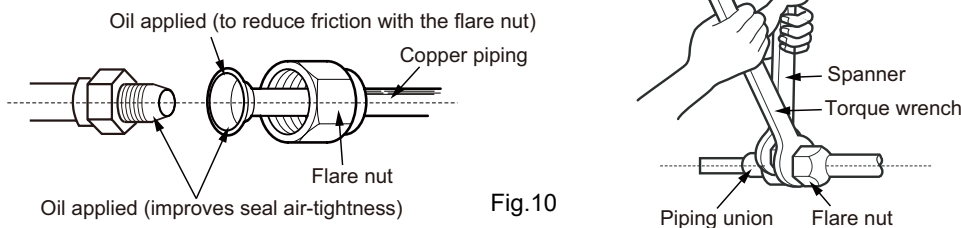

Fig.10

Pipe Diameter (Inch)	1/4"	3/8"	1/2"	5/8"	3/4"	7/8"
Tightening Torque (N·m)	15-30	35-40	45-50	60-65	70-75	80-85

CAUTION!

Be sure to connect the gas pipe after connecting the liquid pipe completely.

d. Checking the Pipe Connections for Gas Leaking

For both indoor and outdoor unit side, check the joints for gas leaking by the use of a gas leakage detector without fail when the pipes are connected.

e. Heat Insulation on the Pipe Joints

Stick coupler heat insulation (large and small) to the place where connecting pipes.

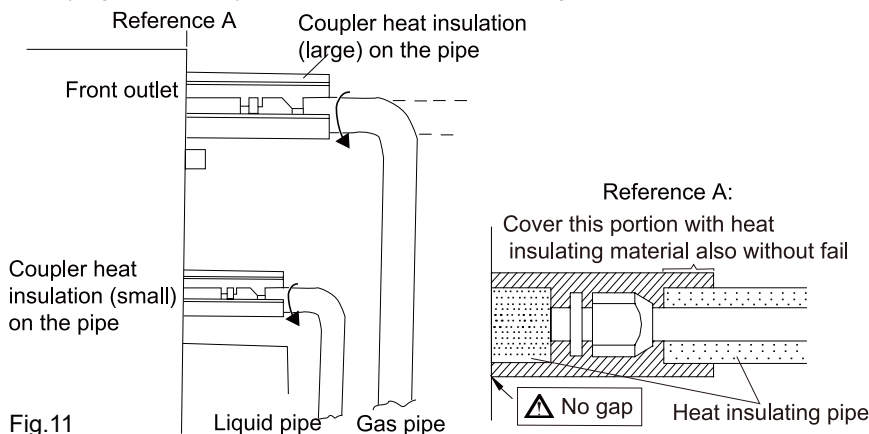

Fig.11

Installation of the Drain Hose

a. Installation of Drain Piping

CAUTION!

Install the drain hose in accordance with the instructions in this installation manual and keep the area warm enough to prevent condensation. Problems with the piping may lead to water leaks.

1. Install the drain hose with downward gradient (1/50 to 1/100) and no risers or traps are used for the hose.(Fig.12)
2. Be sure there is no crack or leak on the drain hose to avoid the formation of air pocket. (Fig.15)
3. When the hose is long, install supporters.(Fig.13)
4. Always use the drain hose which has been insulated properly.
5. Use a suitable drain hose, and see Table 3 for its size.
6. There is a drain port on both the left and right sides. Select the drain port to match the local conditions.(Fig.14)
7. When the unit is shipped from the factory, the drain port is defaulted to be the one on the left side (electric box side), the port on right side has been plugged.

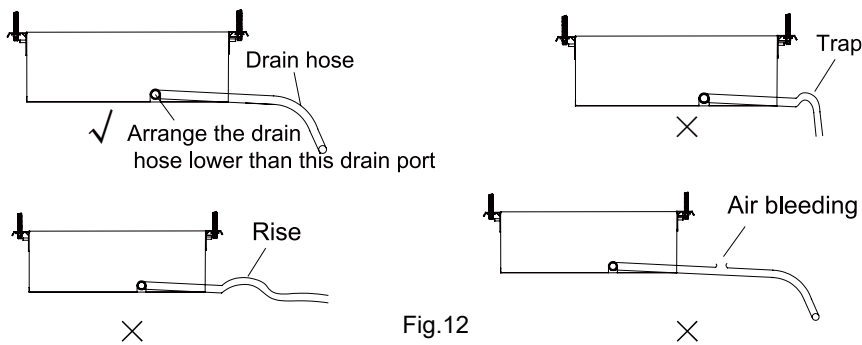

Fig.12

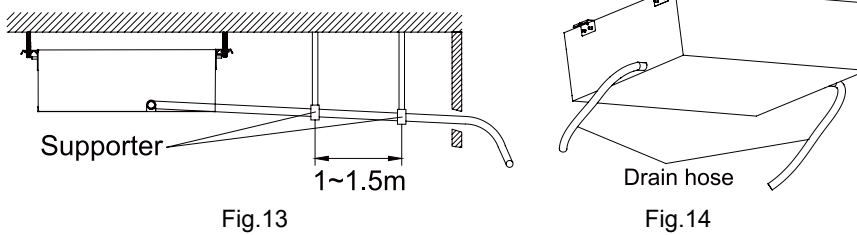

Fig.13

Fig.14

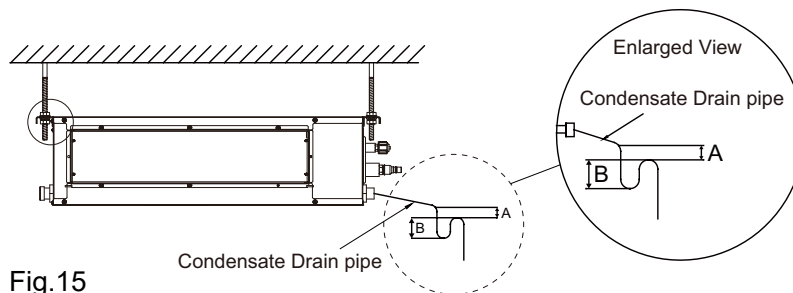

Fig.15

As the inside of the unit is in the negative pressure status, it is required to set up a backwater elbow.

The requirements is: $A=B \geq P/10+20(\text{mm})$

P is the absolute pressure inside the unit. The unit of the pressure is Pa.

8. When using the drain port on the right side of the unit, reinstall the drain cap to the left side drain port.(Fig.16)

CAUTION!

Always check that the drain cap is installed to the unused drain port and is fastened with the nylon fastener. If the drain cap is not installed, or is not sufficiently fastened by the nylon fastener, water may drip during the cooling operation.

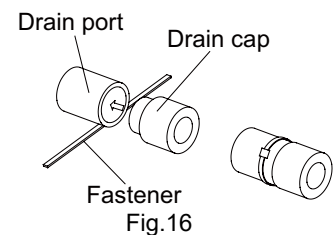

Fig.16

9. Be sure to insulate where the drain port and the drain hose is connected.(Fig.17)
10. The unused drain port also should be insulated properly.(Fig.18)
11. There is adhesive on one side of the insulation so that after removing the protective paper over it the insulation can be directly attached to the drain hose.

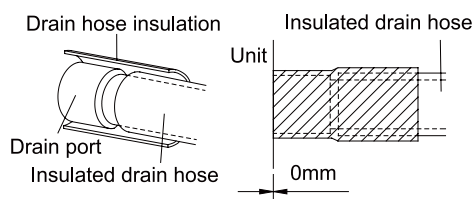

Fig.17

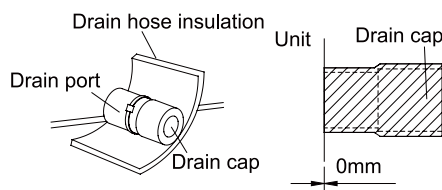

Fig.18

b. Testing of Drain Piping

After piping work is finished, check if drainage flows smoothly .

As shown in the figure, add approximately 1 liter of water slowly into the drain pan and check drainage flow during COO running.

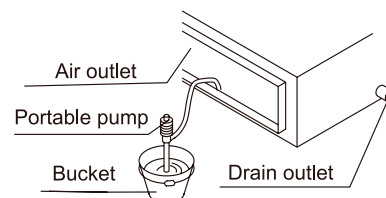

Fig.19

Installation of the Duct

a. Dimensions of the Supply Air Outlet/Return Air Inlet

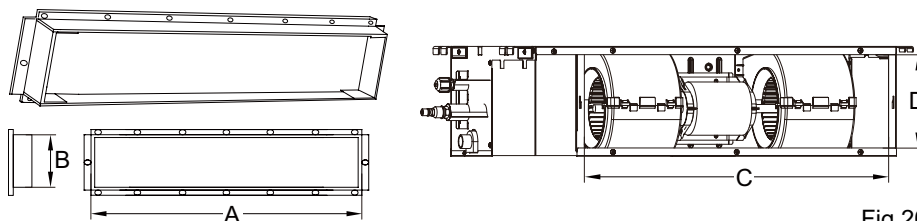

Fig.20

Units: mm

Model	Item	Air Supply Outlet		Return Air Inlet	
		A	B	C	D
09K		538	122	590	170
12K		538	122	590	170
18K		808	122	890	170
24K		1108	122	1190	170

b. Installation of the Air Supply Duct

1. Installation of the rectangular air supply duct

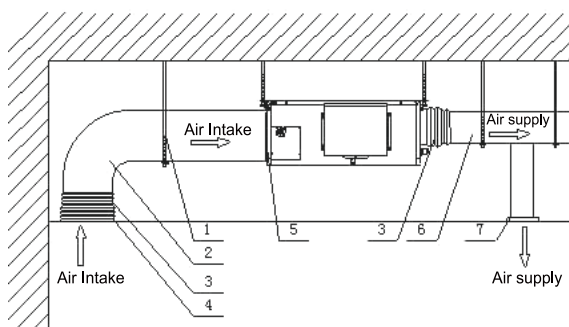

Fig.21

No.	Name	No.	Name
1	Hanger	5	Filter
2	Air Intake Pipe	6	Main Air Supply Pipe
3	Canvas Air Pipe	7	Air Supply Outlet
4	Air Intake		

CAUTION!

- The maximum length of the duct means the maximum length of the supply air duct plus the maximum length of the return air duct.
- The duct is rectangular and connected with the air inlet/outlet of the indoor unit. Among all supply air outlets, at least one should be kept open.

2. The default installation location of the rectangular flange is at the back and the return air cover plate is at the bottom, as shown in Fig.22

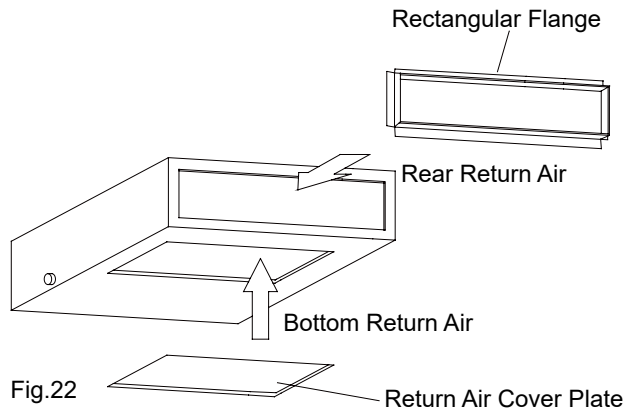

3. If the bottom return air is desired, just change the place of the rectangular flange and the return air cover plate
4. Connect one end of the return air duct to the return air outlet of the unit by rivets and the other to the return air louver. For the sake of the convenience to freely adjust the height, a cutting of canvas duct will be helpful, which can be reinforced and folded by 8# iron wire.
5. More noise is likely to be produced in the bottom return air mode than the backward return air mode, so it is suggested to install a silencer and a static pressure box to minimize the noise.
6. The installation method can be chosen with considering the conditions of the building and maintenance etc., as shown in Fig.23.

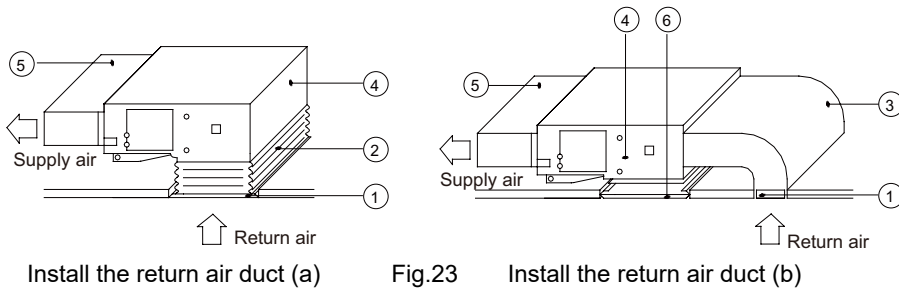

No.	1	2	3	4	5	6
Name	Return Air Inlet (with filter)	Canvas Duct	Return Air Duct	Indoor unit	Supply Air Duct	Grille

Filter Installation

a. Install the air inlet frame

Fasten the air inlet frame on the unit by the screw.

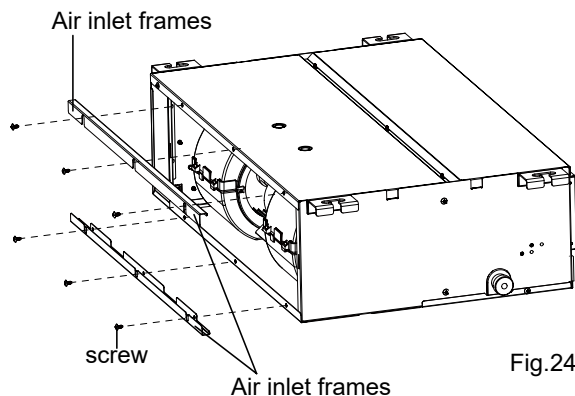
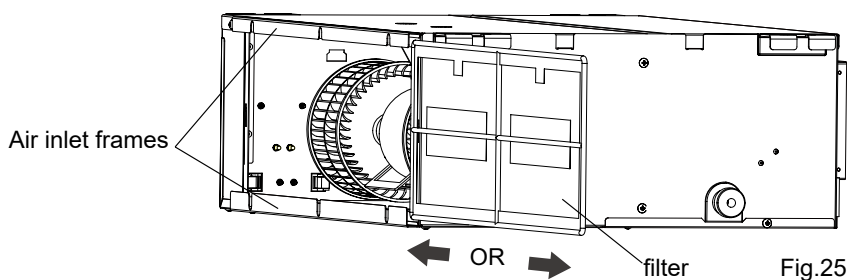

Fig.24

b. Install the filter.

Push the filter into the air inlet frames through the right or left side



Or, carry the filter from down to upper and then push the filter into the air inlet frames.

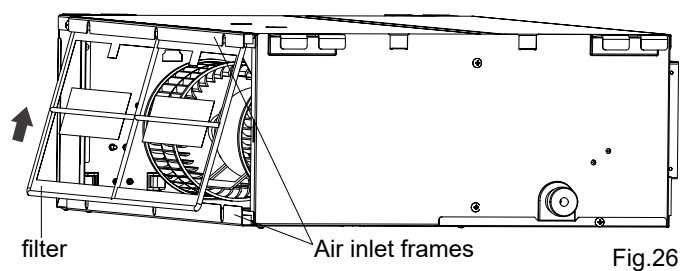

Electrical Wiring

a. Wiring Precautions



WARNING!

- Before obtaining access to terminals, all supply circuits must be disconnected.
- The rated voltage of the unit is as shown as table 7.
- Before turning on, verify that the voltage is within the 198~264V range.
- Perform wiring work in accordance with standards so that the air conditioner can be operated safely and positively.

Model	Power Supply	Recommended Cord (pieces×sectional area)
09K	220-240V~,50Hz	4×0.75mm ²
12K	220-240V~,50Hz	4×0.75mm ²
18K	220-240V~,50Hz	4×0.75mm ²
24K	220-240V~,50Hz	4×0.75mm ²

b. Electrical Wiring

1. For solid core wiring (Fig.27)

- (1). Cut the wire end with a wire cutter or wire-cutting pliers, then strip the insulation about 25mm (15/16") .
- (2). Using a screwdriver, remove the terminal screw(s) on the terminal board.
- (3). Using pliers, bend the solid wire to form a loop suitable for the terminal screw.
- (4). Shape the loop wire properly, place it on the terminal board and tighten securely with the terminal screw using a screwdriver.

2. For strand wiring (Fig.27)

- (1). Cut the wire end with a wire cutter or wire-cutting pliers, then strip the insulation about 10mm (3/8") .
- (2). Using a screwdriver, remove the terminal screw (s) on the terminal board.
- (3). Using a round terminal fastener or pliers, securely clamp a round terminal to each stripped wire end.
- (4). Position the round terminal wire, and replace and tighten the terminal screw with a screwdriver.(Fig.28)

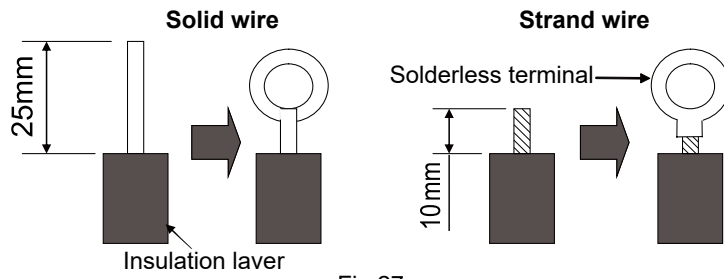

Fig.27

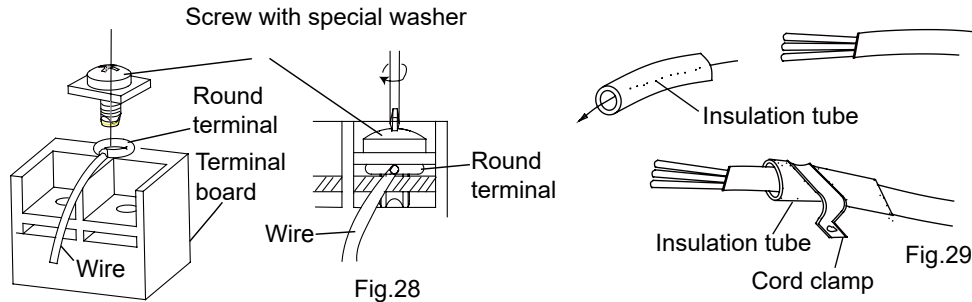

Fig.28

Fig.29

3. How to fix connection cord and power cord by cord clamp

After passing the connection cord and power cord through the insulation tube, fasten it with the cord clamp.(Fig.29)

CAUTION!

- Before starting work, check that power is not being supplied to the outdoor unit.
- Match the terminal block numbers and connection cord colors with those of the indoor unit side.
- Erroneous wiring may cause burning of the electric parts.
- Connect the connection cords firmly to the terminal block. Imperfect installation may cause a fire.
- Always fasten the outside covering of the connection cord with cord clamps. (If the insulator is not clamped, electric leakage may occur.)
- Always connect the ground wire.

4. Wiring of the Power Cord

CAUTION!

The power supply for each indoor unit must be uniform.

- Dismantle the cover of the electric box of the indoor unit.
- Let the power cord go through the rubber ring.
- Connect the wiring (communication) through the piping hole of the chassis and the bottom of the appliance upward, then connect the brown wire to the terminal board "3"; black wire(the communication wire) to the terminal board "2"; blue wire to the box. Clamp them with the corresponding wire clamp packed in the chassis.
- Fix the power cord tightly with the binding wire.

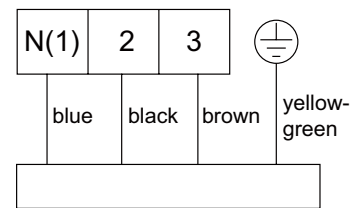

Outdoor unit connection

Fig.30

Installation of the Wired Controller

Refer to the Installation Manual of the wired controller for more details.

8. Exploded Views and Parts List

8.1 Indoor Unit

Model: 09K/12K

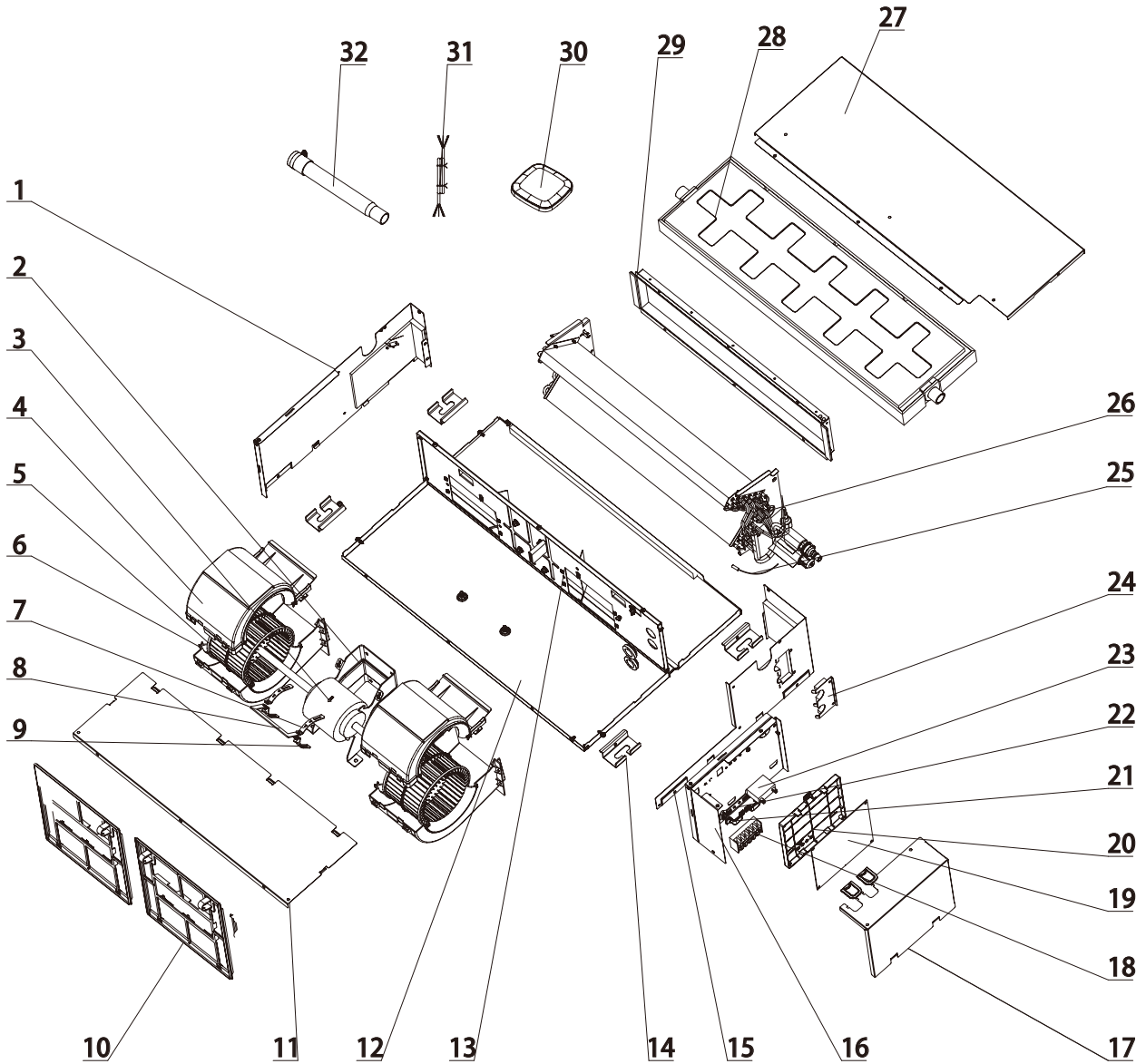

No.	Description	Part Code		Qty
		DBIS-09(I)	DBIS-12(I)	
		Product Code	Product Code	
1	left-side plate assembly	K1060001601	K1060001601	1
2	motor support	K11200014	K11200014	1
3	Motor	K1680001102	K1680001202	1
4	under Volute	K15800006	K15800006	2
5	centrifugal fan subassembly	K14420005	K14420005	2
6	up volute	K15800007	K15800007	2
7	motor clamp	K6080000301	K6080000301	2
8	motor loop clamp	K60800004	K60800004	1
9	motor clamp subassembly	K60800002	K60800002	2
10	air filter subassembly	K15420035	K15420035	2
11	under cover plate 2	K11020004	K11020004	1
12	top cover assembly	K11020002	K11020002	1
13	motor installation plate subassembly	K11230003	K11230003	1
14	hang hook	K11410003	K11410003	4
15	right-side Plate assembly	K10600014	K10600014	1
16	electrical box subassembly	K10810003	K10810003	1
17	electrical box cover	K10450036	K10450036	2
18	wiring board	K33600008	K33600008	1
19	mainboard	K30050207	K30050207	1
20	mainboard installation box	K20410002	K20410002	1
21	wire clamp	K61000003	K61000003	1
22	insulation gasket	K60600004	K60600004	2
23	Capacitor	K3122000104	K3122000104	1
24	outlet nozzle sealed plate subassembly	K11460002	K11460002	1
25	temp. Sensor	K33000001	K33000001	1
26	evaporator subassembly	K10200040	K10200060	1
27	under cover plate 1	K11020003	K11020003	1
28	drain pan assembly	K16410001	K16410001	1
29	wind-casing assembly	K11260009	K11260009	1
30	Wired controller	K30030003	K30030003	1
31	connection wire in PCB (4 core)	K3321000202	K3321000202	1
32	drain pipe subassembly	K13010004	K13010004	1

Model: 18K

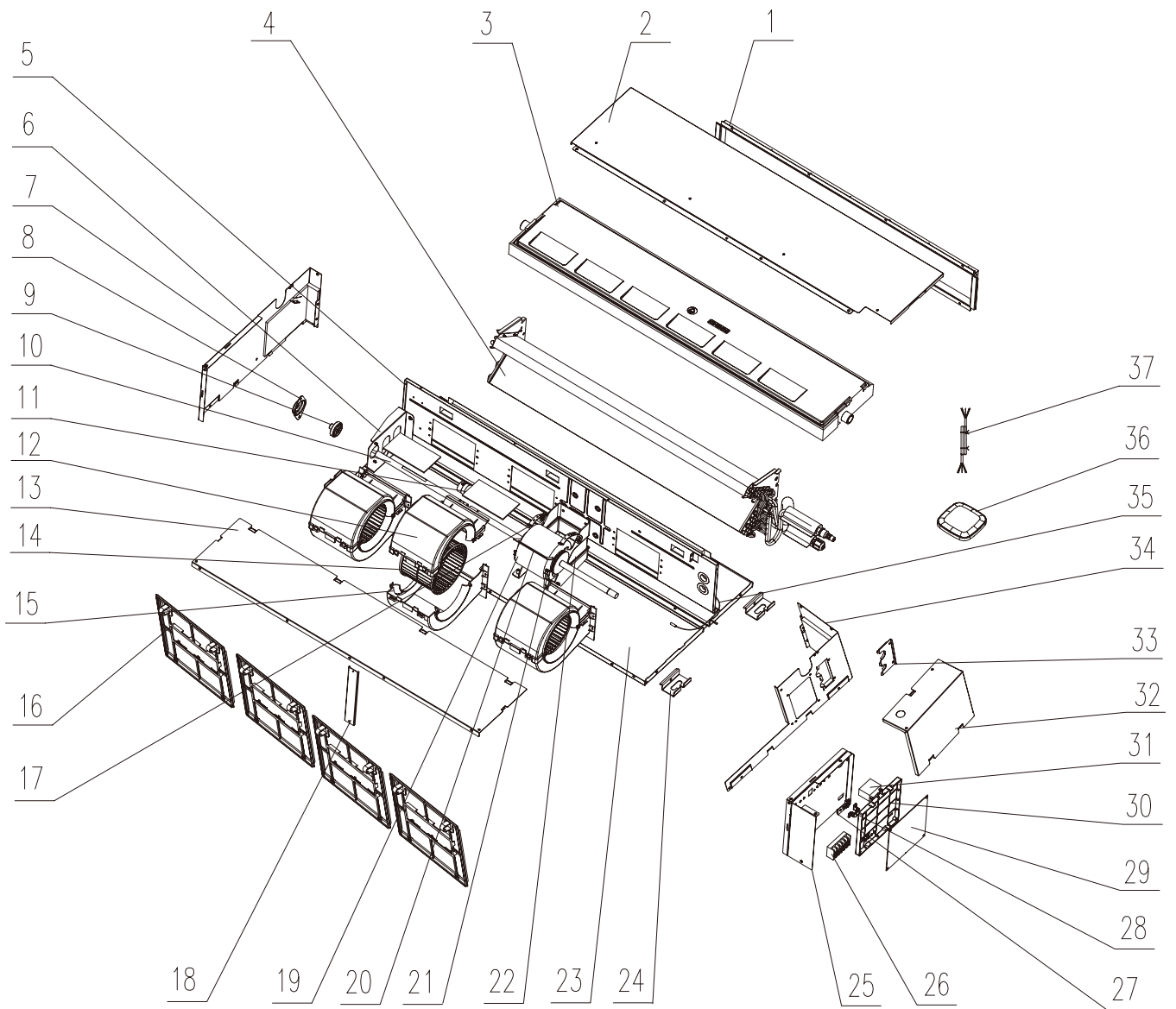

No.	Description	Part Code	Qty
		DBIS-18(I)/D	
		Product Code	
		KEF001N0140	
1	wind-casing assembly	K11260017	1
2	under cover plate 1	K20600016	1
3	drain pan assembly	K16410008	1
4	evaporator subassembly	K10200059	1
5	motor installation plate subassembly	K11230010	1
6	Bearing Pedestal(left)	K22040004	1
7	left-side plate assembly	K1060001601	1
8	bearing installation case	K10610001	1
9	bearing gum ring subassembly	K62400007	1
10	rotate axis subassembly	K61200010	1
11	coupling	K61200009	1
12	under Volute	K15800007	3
13	under cover plate 2	K20600017	1
14	centrifugal fan subassembly	K14420005	3
15	up volute	K15800006	3
16	air filter subassembly	K15420035	3
17	motor clamp	K6080000301	2
18	Support	K11280001	1
19	Motor	K1680003201	1
20	motor loop clamp	K60800004	1
21	motor clamp subassembly	K60800002	2
22	motor support	K11200014	1
23	top cover assembly	K20600013	1
24	hang hook	K11410003	4
25	electrical box subassembly	K10810003	1
26	wiring board	K33600008	1
27	insulation gasket	K60600004	1
28	wire clamp	K61000003	1
29	mainboard	K30050207	1
30	mainboard installation box	K20410002	1
31	Capacitor	K3122000104	1
32	electrical box cover	K10450036	1
33	outlet nozzle sealed plate subassembly	K11460002	1
34	right-side Plate assembly	K10600021	1
35	temp. Sensor	K33000001	1
36	Wired controller	K30030003	1
37	connection wire in PCB (4 core)	K3321000202	1

Model: 24K

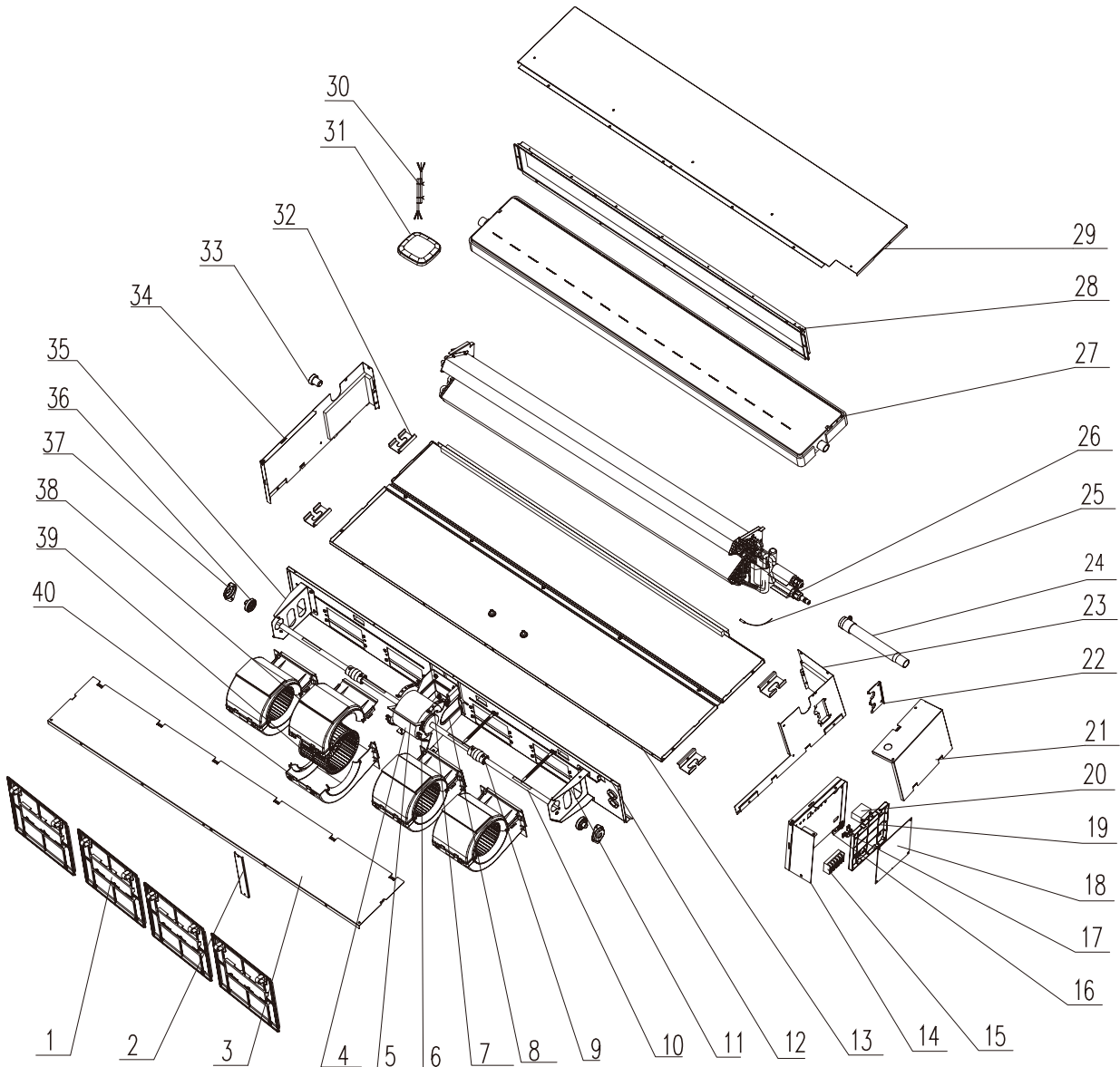

No.	Description	Part Code	Qty
		DBIS-24(I)	
		Product Code KEF001N0150	
1	air filter subassembly	K15420035	4
2	Support	K11280001	1
3	under cover plate 2	K20600008	1
4	Motor	K16800032	1
5	motor loop clamp	K60800004	1
6	motor clamp subassembly	K60800002	2
7	motor clamp	K6080000301	2
8	motor support	K11200014	1
9	coupling	K61200009	2
10	rotate axis subassembly	K61200010	2
11	Bearing Pedestal(right)	K22040005	1
12	motor installation plate subassembly	K11230009	1
13	top cover assembly	K20600005	1
14	electrical box subassembly	K10810003	1
15	wiring board	K33600027	1
16	insulation gasket	K60600004	1
17	wire clamp	K61000003	1
18	mainboard	K30050207	1
19	mainboard installation box	K20410002	1
20	Capacitor	K3122000106	1
21	electrical box cover	K20400026	1
22	outlet nozzle sealed plate subassembly	K11460002	1
23	right-side Plate assembly	K10600021	1
24	drain pipe subassembly	K13010004	1
25	temp. Sensor	K33000001	1
26	evaporator subassembly	K10200038	1
27	drain pan assembly	K16410004	1
28	wind-casing assembly	K11260015	1
29	under cover plate 1	K20600007	1
30	connection wire in PCB (4 core)	K3321000202	1
31	Wired controller	K30030003	1
32	hang hook	K11410003	4
33	drain pan stopper	K62600017	1
34	left-side plate assembly	K1060001601	1
35	Bearing Pedestal(left)	K22040004	1
36	bearing gum ring subassembly	K62400007	2
37	bearing installation case	K10610001	2
38	up volute	K15800007	4
39	centrifugal fan subassembly	K14420005	4
40	under Volute	K15800006	4

9. Troubleshooting

9.1 Error Code List

Error Code	Name of malfunction and status	Way of display			Error Type	Possible Causes	Solution
		Display directly	By remote control procedure only	By remote control procedure within compressor stop 200s or directly after compressor stop 200s			
CL	Filter cleaning reminder	√			Indoor	Filter may have dust	Clean the flite
d0	Compressor RMS phase current limit down		√		Outdoor	Compressor phase current effective value is too high, the compressor need to limit the frequency or frequency reduction operation	The normal limit frequency reduction function.
d1	RMS machine current limit down		√		Outdoor	The whole unit current effective value is too high, compressor need to limit the frequency or frequency reduction operation	The normal limit frequency reduction function.
d2	Exhaust gas temperature limit down		√		Outdoor	The Exhaust pipe temperature is too high, compressor need to limit the frequency or frequency reduction operation	The normal limit frequency reduction function.
d3	Anti-freeze limit down		√		Outdoor	The inner pipe temperature is too low, compressor need to limit the frequency or frequency reduction operation	The normal limit frequency reduction function.
d4	Overload limit down		√		Outdoor	The system is overload, compressor need to limit the frequency or frequency reduction operation	The normal limit frequency reduction function.
d5	IPM temp limit down		√		Outdoor	The compressor module temperature is too high, compressor need to limit the frequency or frequency reduction operation	The normal limit frequency reduction function
E0	High discharge temp protection			√	Outdoor	See Diagram 1	See Diagram 1
E1	Overload protection			√	Outdoor	See Diagram 2	See Diagram 2
E2	Compressor overload protection			√	Outdoor	See Diagram 3	See Diagram 3
E3	Anti-freeze protection			√	Outdoor	1. Indoor machine return air is not smooth. 2. The fan speed is too low. 3. The filter or evaporator not clean. 4. The inner temperature sensor abnormal.	1. Indoor machine return air is not smooth. 2. The fan speed is too low. 3. The filter or evaporator not clean. 4. Change the temperature sensor abnormal.
E7	4 way valve malfunction			√	Outdoor	1. Supply voltage is unstable 2. Mainboard and 4-Way valve unconnected. 3. 4-Way valve is broken.	1. Check the voltage of power supply. 2. Check the connecting of mainboard and 4-way valve. 3. Change the 4-Way valve.
E8	Outdoor ambient temperature abnormal protection		√		Outdoor	1. The outdoor environment temperature is too high or too low. 2. The outdoor environment temprature sensor is damage.	1. The outdoor environment temperature is in normal range. 2. Change the temprature sensor.
H0	Compressor stalling			√	Outdoor	See Diagram 4	See Diagram 4
H1	Start up failure			√	Outdoor	See Diagram 5	See Diagram 5

H2	Compressor phase current peak protection			√	Outdoor	See Diagram 6	See Diagram 6
H3	Compressor phase current RMS protection			√	Outdoor	See Diagram 7	See Diagram 7
H4	IPM protection			√	Outdoor	See Diagram 8	See Diagram 8
H5	IPM overheat protection			√	Outdoor	1. The radiator ventilation is abnormal 2. IPM module thermal paste dry solid or screw loose 3. the mainboard is damage	1. Check the radiator ventilation is normal 2. Check the IPM module thermal paste dry solid or screw loose is normal 3. Change the main board
H6	Compressor phase ciurcuit detection error	√			Outdoor	the mainboard is broken	change the mainboard
H7	Compressor phase loss error			√	Outdoor	1.mainboard and compressor unconnected 2.the mainboard is broken	1.check the connecting of mainboard and compressor 2.change the mainboard
H8	Outdoor DC fan motor error			√	Outdoor	1.Outdoor motor fan is blocked 2.mainboard and DC fan motor unconnected 3.the mainboard is broken 4.DC fan motor is broken	1.remove the block 2.check the connecting of mainboard and DC fan motor 3.change the mainboard 4.change the DC fan motor
H9	Outdoor DC fan motor phase current detection circuit error	√			Outdoor	The mainboard is broken	Change the mainboard
L0	Jumper error	√			Indoor	See Diagram 9	See Diagram 9
L1	PG Indoor motor zero crossing detecting circuit malfunction	√			Indoor	The mainboard is broken	Change the mainboard
L2	Indoor fan motor error	√			Indoor	See Diagram 10	See Diagram 10
L3	Indoor display communication between Indoor and Outdoor failure	√			Indoor	See Diagram 11	See Diagram 11
L4	Select the port level abnormal error		√		Indoor	The mainboard is broken	Change the mainboard
L5	Indoor EEPROM error		√		Indoor	See Diagram	See Diagram
L6	Outdoor display communication between Indoor and Outdoor failure	√			Outdoor	See Diagram 12	See Diagram 12
LL	Trial running		√		Indoor	Normal Function	Normal Function
P0	Outdoor EEPROM error	√			Outdoor	1.EEPROM chip(U8)loose. 2.The mainboard is broken.	1.Check the EEPROM chip(U8)is fixed. 2.Change the mainboard.
P1	Power On failure \ Chaging ciurcuit error	√			Outdoor	1.The voltage of power supply is too low. 2.The mainboard is broken.	1.Check the voltage of power supply. 2.Change the mainboard.
P2	Alternating current protection \ Feedforward voltage protection			√	Outdoor	1.The voltage of power supply is too low. 2.The mainboard is broken	1.Check the voltage of power supply. 2.Change the mainboard.
P3	High voltage protection			√	outdoor	1.The voltage of power supply is too high. 2.The mainboard is broken.	1.Check the voltage of power supply. 2.Change the mainboard.
P4	Low voltage protection			√	Outdoor	1.The voltage of power supply is too low. 2.The mainboard is broken.	1.Check the voltage of power supply. 2.Change the mainboard.
P5	DC line voltage drop protection			√	Outdoor	1.The voltage of power supply is unstable. 2.The mainboard is broken.	1.Check the voltage of power supply. 2.Change the mainboard.
P6	Machine current detection circuit error	√			Outdoor	1.Refrigerant leakage. 2.The mainboard is broken.	1.Check the refrigerant leakage. 2.Change the mainboard.
P7	Over-current protection			√	Outdoor	See Diagram 13	See Diagram 13
P8	PFC current detection circuit error	√			Outdoor	The mainboard is broken	Change the mainboard
P9	PFC protection			√	Outdoor	See Diagram 14	See Diagram 14

PA	Indoor and outdoor mismatch	√			Outdoor	1. The outdoor unit valve is close. 2. The refrigerant connecting pipe installation errors. 3. The inside and outside the machine connecting wiring error. 4. The refrigerant connecting pipe with the connection order sequence.	1. Check the outdoor unit valve is open. 2. The refrigerant connecting pipe installation errors. 3. Check the inside and outside the machine connecting wiring is correct. 4. Check the refrigerant connecting pipe with the connection is in order sequence.
PC	Mode conflic	√			Outdoor	Failure in indoor model conflicts with the operation mode of the outdoor unit.	Power off or change the failure in indoor unit mode to non-conflicts mode
U0	Indoor ambiet temp sensor short/open	√			Indoor	1.The wiring terminal between the temperature sensor and the mainboard loosened or poorly contacted. 2.The sensor is broken. 3.The mainboard is broken.	1.Check the wiring terminal. 2.Change the sensor. 3.Change the mainboard.
U1	Indoor mide pepe temp sensor short/open	√			Indoor	1.The wiring terminal between the temperature sensor and the mainboard loosened or poorly contacted. 2.The sensor is broken. 3.The mainboard is broken.	1.Check the wiring terminal. 2.Change the sensor. 3.Change the mainboard.
U2	Outdoor ambient temp sensor short/open	√			Outdoor	1.The wiring terminal between the temperature sensor and the mainboard loosened or poorly contacted. 2.The sensor is broken. 3.The mainboard is broken.	1.Check the wiring terminal. 2.Change the sensor. 3.Change the mainboard.
U3	Outdoor mid-coil temp sensor short/open	√			Outdoor	1.The wiring terminal between the temperature sensor and the mainboard loosened or poorly contacted. 2.The sensor is broken. 3.The mainboard is broken.	1.Check the wiring terminal. 2.Change the sensor. 3.Change the mainboard.
U4	Outdoor pipe temp sensor short/open	√			Outdoor	1.The wiring terminal between the temperature sensor and the mainboard loosened or poorly contacted. 2.The sensor is broken. 3.The mainboard is broken.	1.Check the wiring terminal. 2.Change the sensor. 3.Change the mainboard.
U5	IPM temp sensor short/open	√			Outdoor	The IPM temp sensor is broken.	Change the mainboard.
U6	Liquid pipe outlet temp sensor short/open	√			Outdoor	1.The wiring terminal between the temperature sensor and the mainboard loosened or poorly contacted. 2.The sensor is broken. 3.The mainboard is broken.	1.Check the wiring terminal. 2.Change the sensor. 3.Change the mainboard.
U7	Gas pipe outlet temp sensor short/open	√			Outdoor	1.The wiring terminal between the temperature sensor and the mainboard loosened or poorly contacted. 2.The sensor is broken. 3.The mainboard is broken.	1.Check the wiring terminal. 2.Change the sensor. 3.Change the mainboard.
U8	Discharge temp sensor short/open	√			Outdoor	1.Outdoor pipe temp sensor is not in the right position. 2.The sensor is broken. 3.The mainboard is broken.	1.Check the sensor position. 2.Change the sensor. 3.Change the mainboard.

9.2 PCB Printed Diagram

Indoor Unit

- Top View

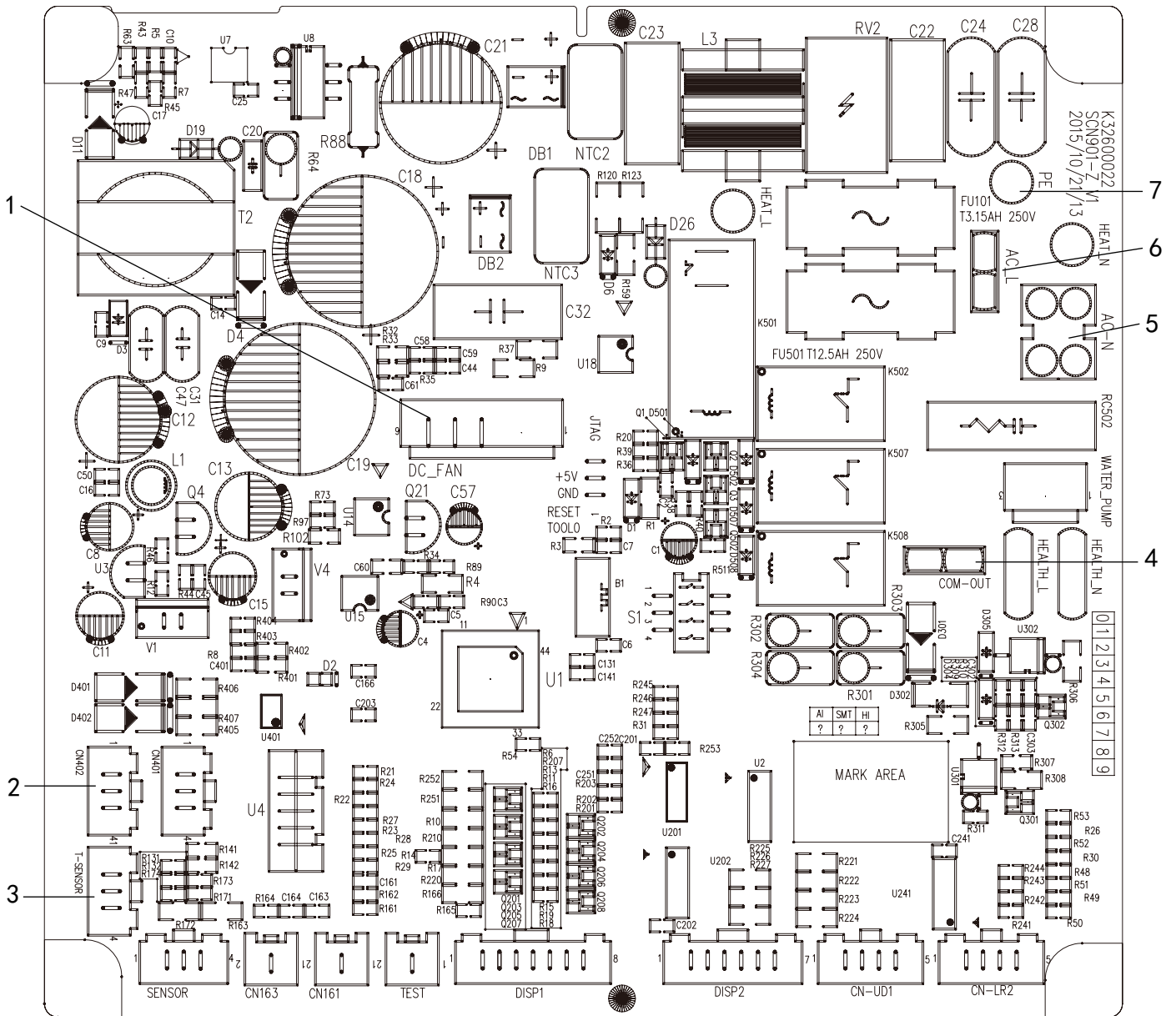

No.	Function
1	Auxiliary heating zero wire connector
2	Cold plasma zero wire connector
3	Power supply zero wire connector
4	AC motor connector
5	Cold plasma fire wire connector
6	AC motor feedback connector
7	Up and down louver motor connector

9.3 Procedure of Troubleshooting

Diagram 1:

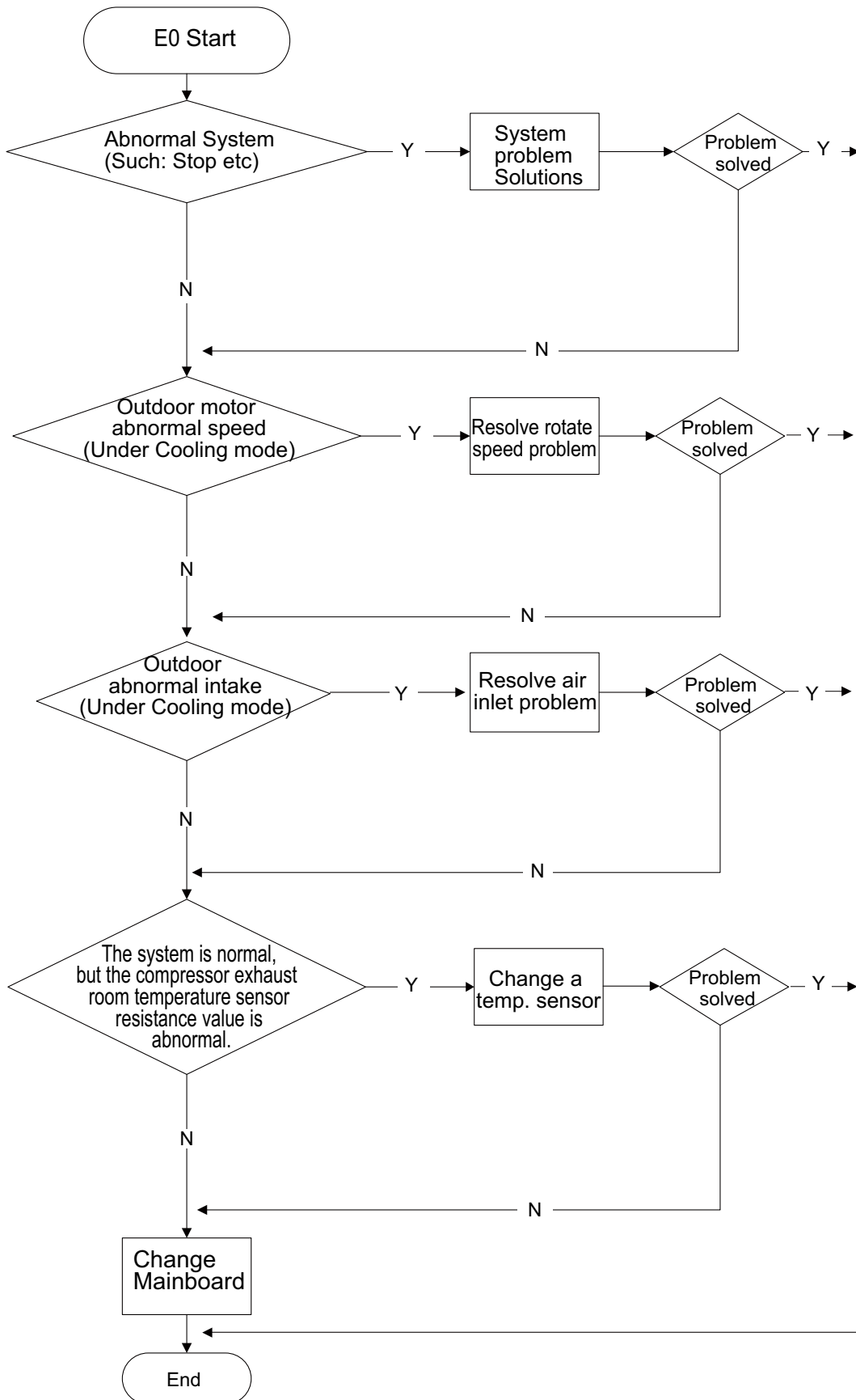

Diagram 2:

Main test points:

- Is the temperature of Indoor and Outdoor Unit too high?
- Is the fan of Indoor and Outdoor Unit operating normal?
- Is the radiating of Indoor and Outdoor Unit well(Including the fan speed is lower or not)?
- Is the pipe temperature sensor normal?

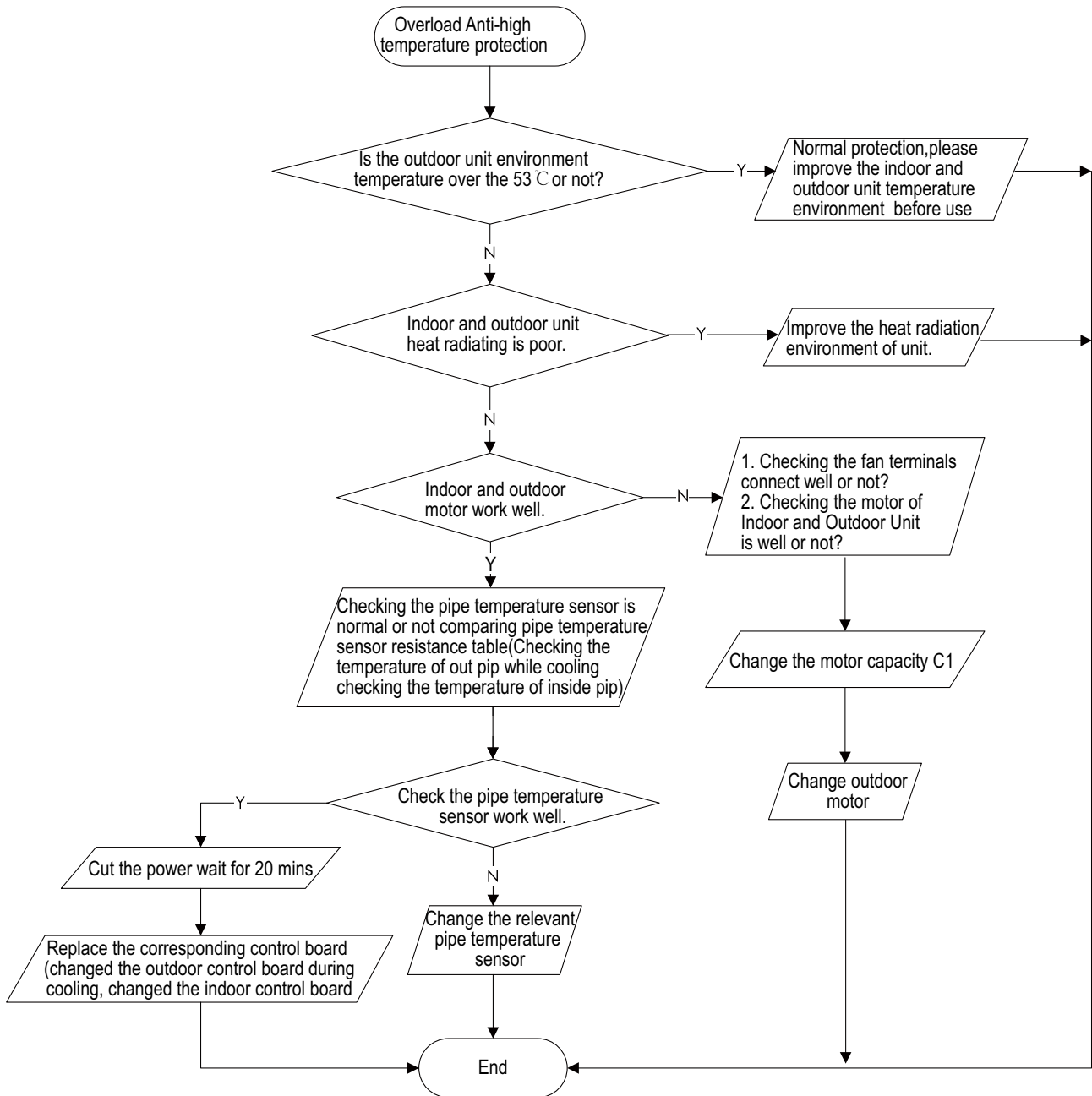

Diagram 3:

Main test points:

- Check the electronic expansion valve is connected.
- Check the electronic expansion valve is in good condition.
- Check the refrigerant leakage or not.
- Check the overload protector is in good condition.
- Check the pipe temperature sensor is in good condition.

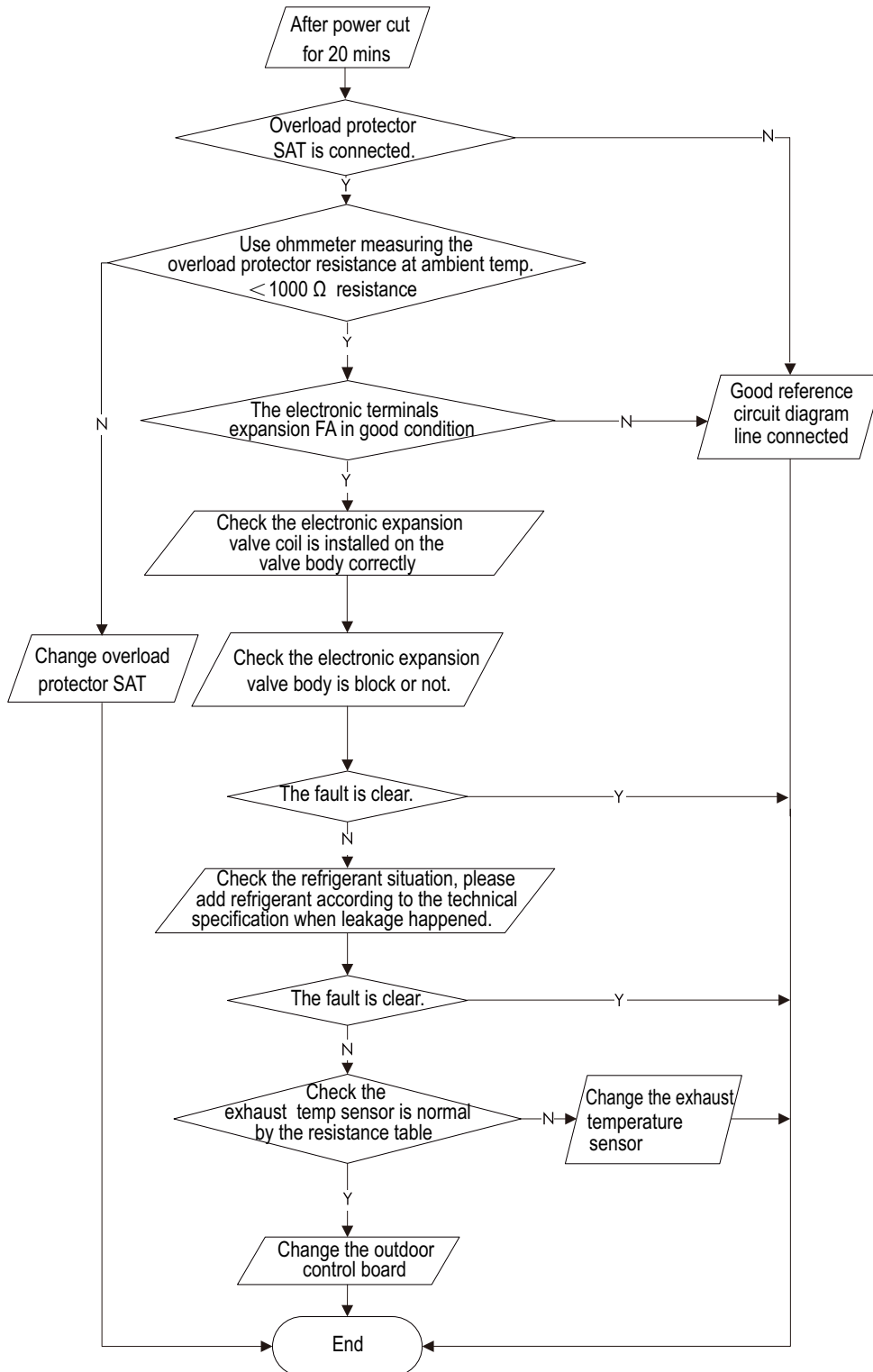

Diagram 4:

Main test points:

- Check the system pressure is high.
- Check the voltage is low.

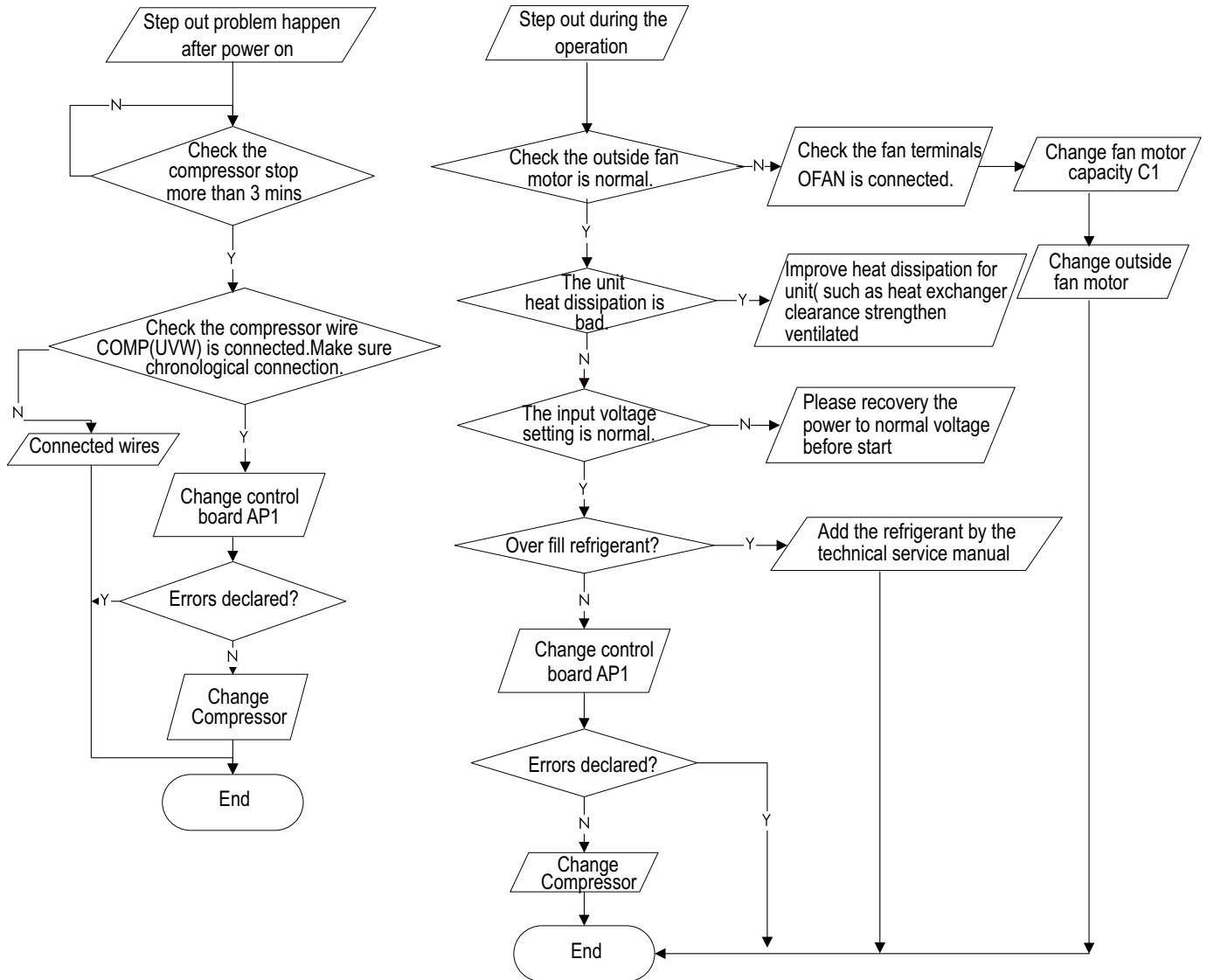

Diagram 5:

Main test points:

- Whether the compressor wiring is connected correct?
- Is compressor broken?
- Is time for compressor stopping enough?
- Whether refrigerant was charged too much?

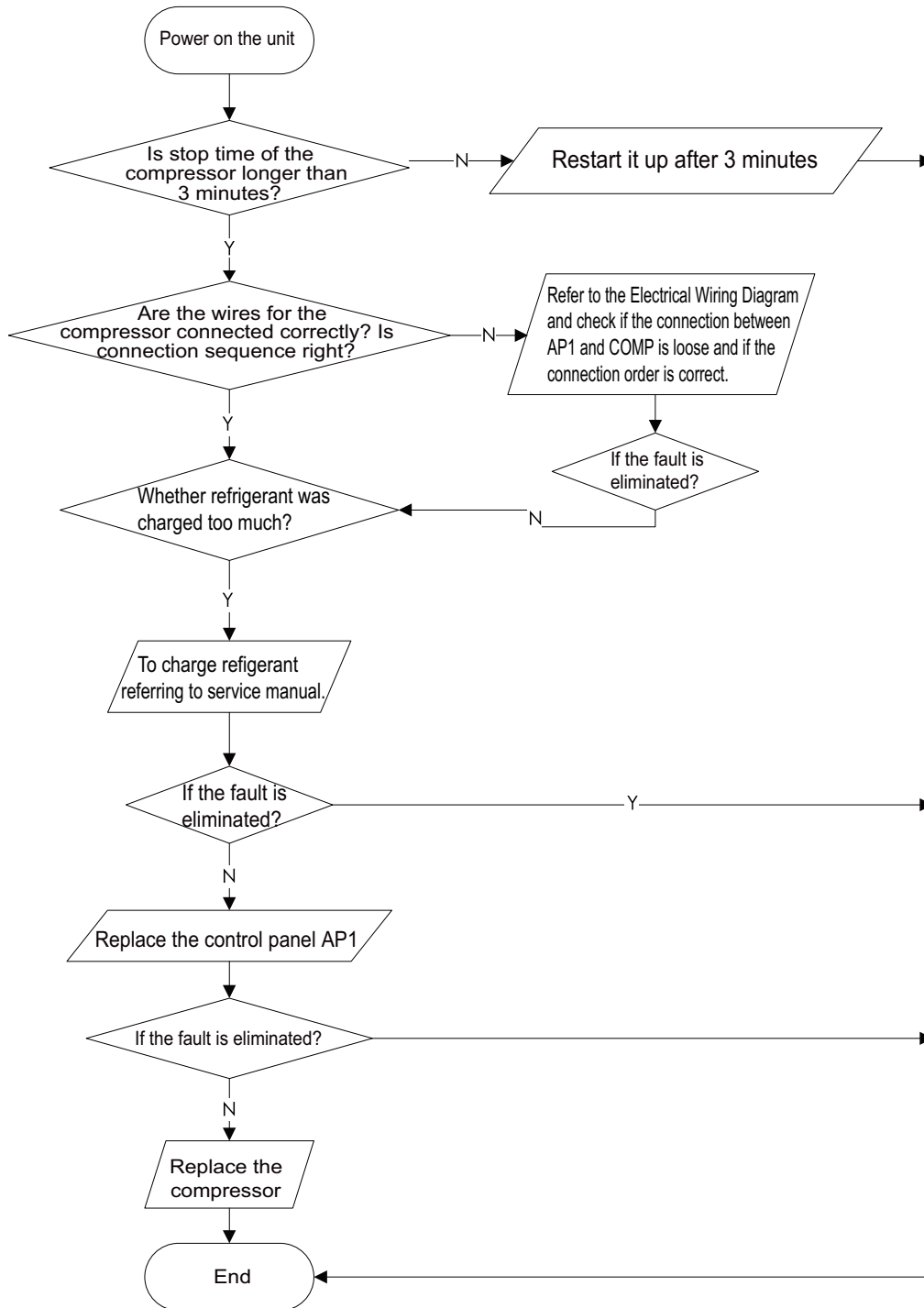

Diagram 6 , 7 , 8:

Main check points:

- Is the connection between control panel AP1 and compressor COMP secure? Loose? Is the connection in correct order?
- Is the voltage input of the machine within normal range? (Use AC voltmeter to measure the voltage between terminal L and N on the wiring board XT)
- Is the compressor coil resistance normal? Is the insulation of compressor coil against the copper tube in good condition?
- Is the working load of the machine too high? Is the radiation good?
- Is the charge volume of refrigerant correct?

Fault diagnosis process:

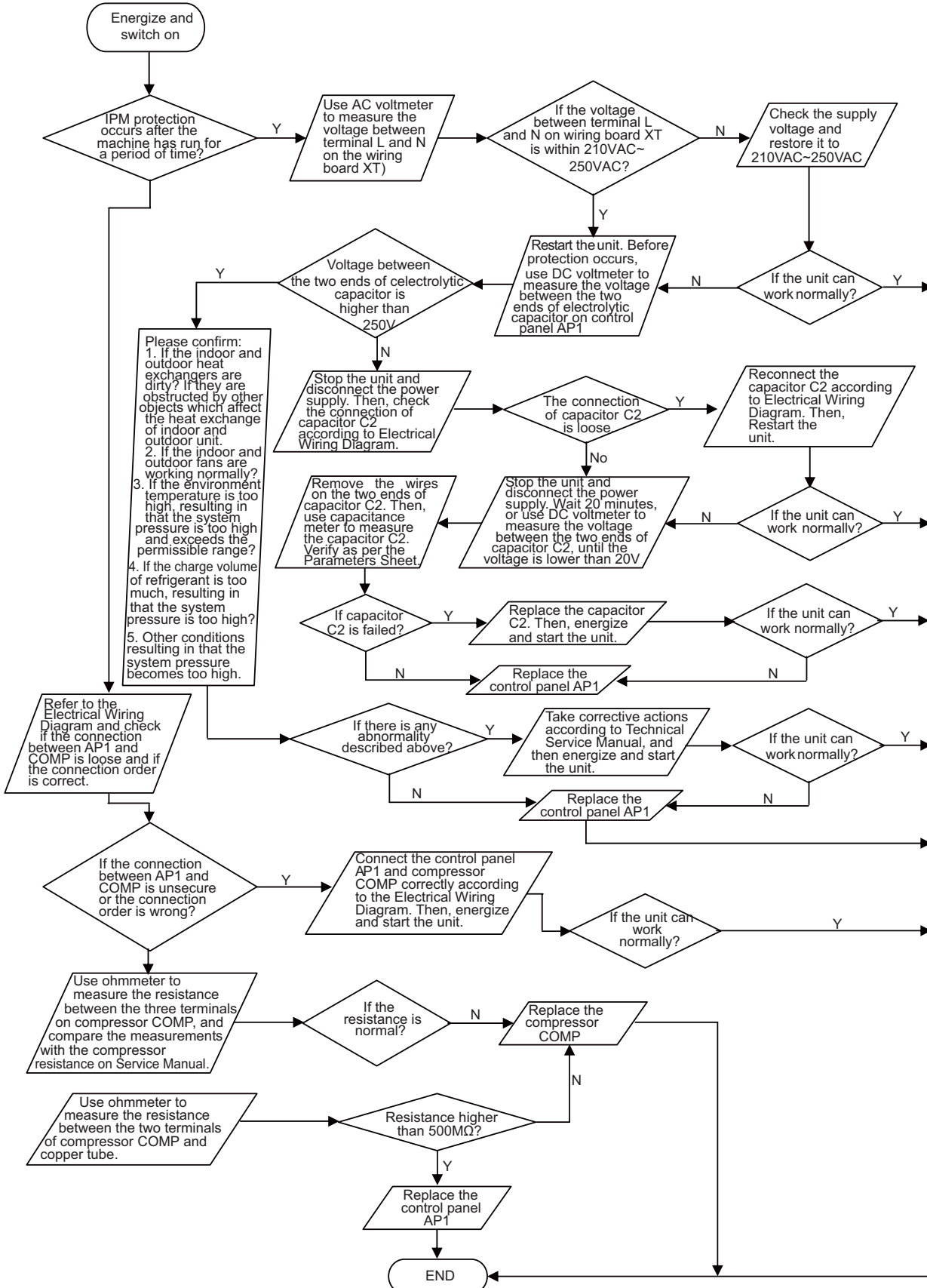

Diagram 9:

Main detection points:

- Is there jumper cap on the main board?
- Is the jumper cap inserted correctly and tightly?
- The jumper is broken?
- The motor is broken?
- Detection circuit of the mainboard is defined abnormal.

Malfunction diagnosis process:

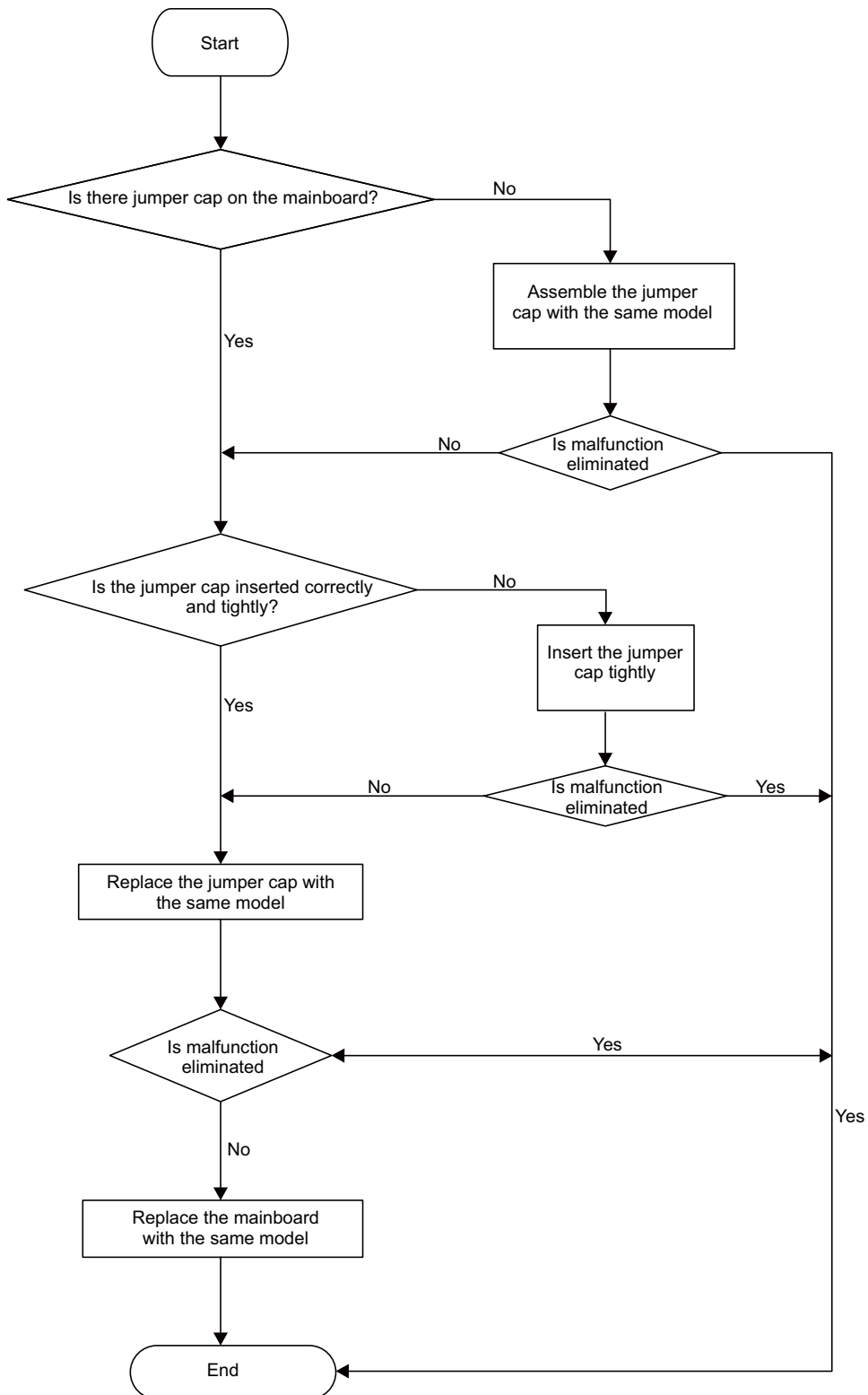

Diagram 10:

Malfunction of Blocked Protection of IDU Fan Motor L2

Main detection points:

- Smoothly Is the control terminal of PG motor connected tightly?
- Smoothly Is the feedback interface of PG motor connected tightly?
- The fan motor can't operate?
- The motor is broken?
- Detection circuit of the mainboard is defined abnormal

Malfunction diagnosis process:

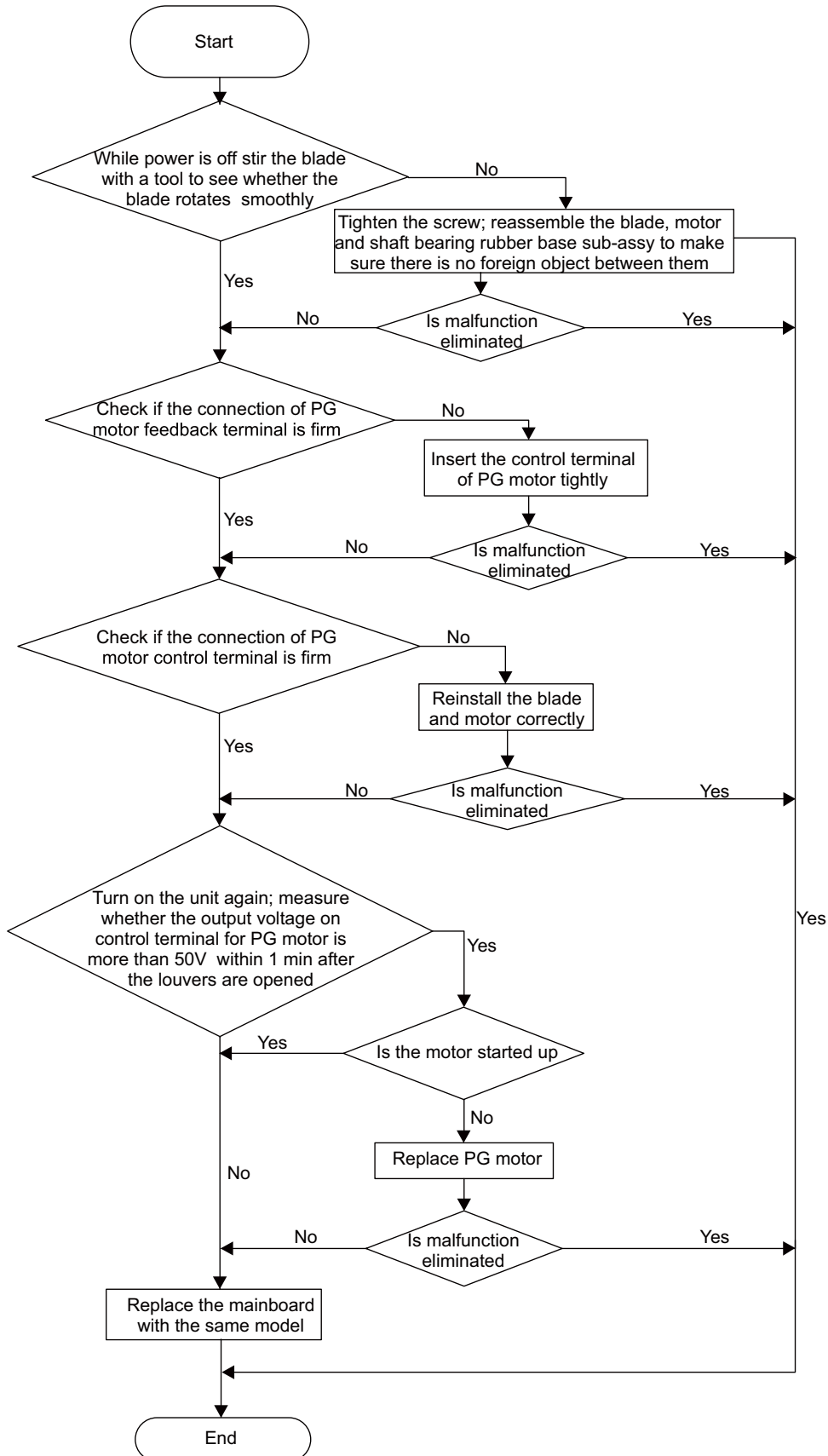

Diagram 11:

Main check points:

- Test the indoor and outdoor unit connection wire and internal wiring is connected or in good condition.
- Check the indoor unit main board communication circuit and outdoor unit main board communication circuit (AP1) are in good condition.

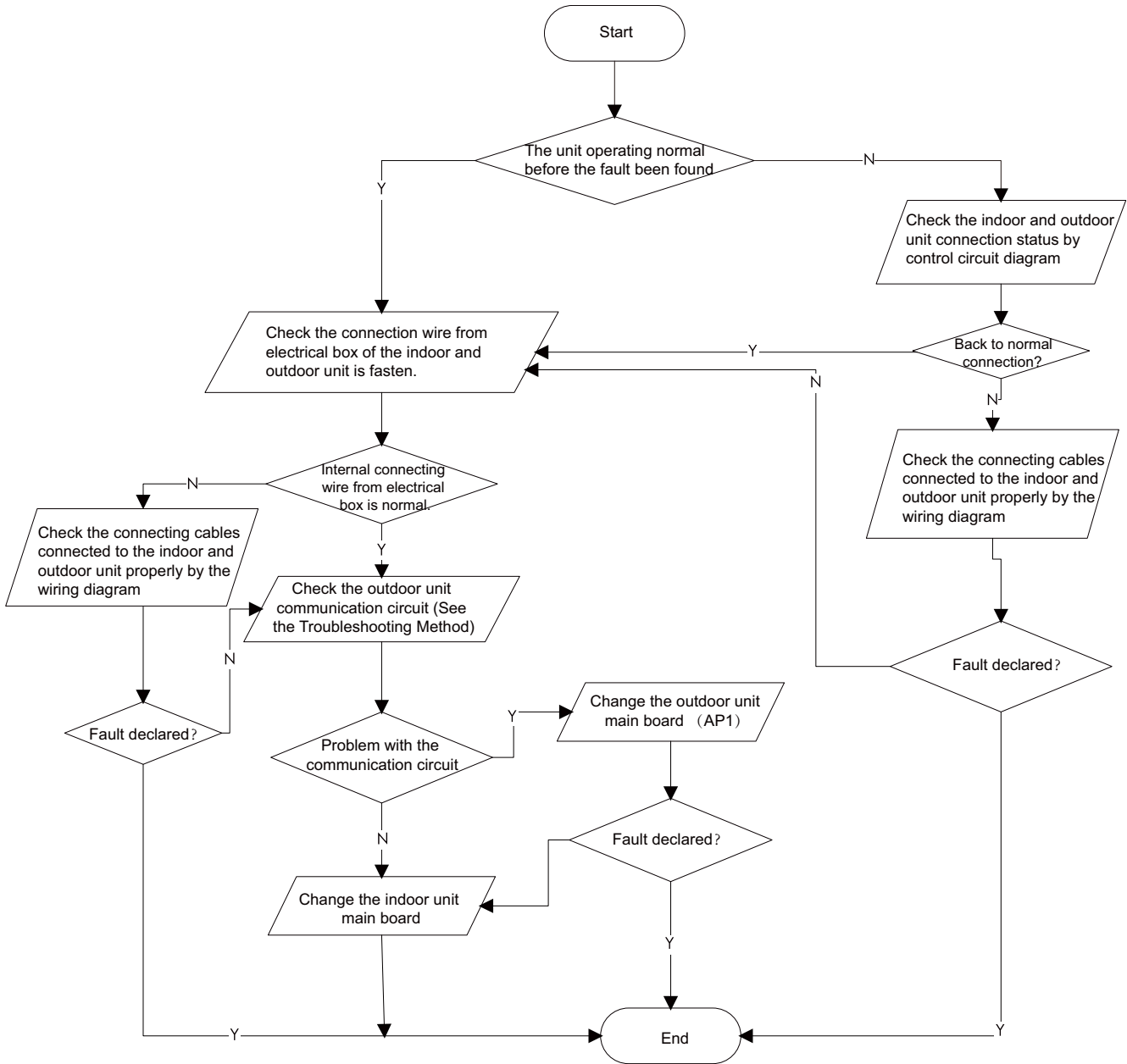

Diagram 12:

Outdoor unit communication circuit detection process as follows (outdoor unit key test points)

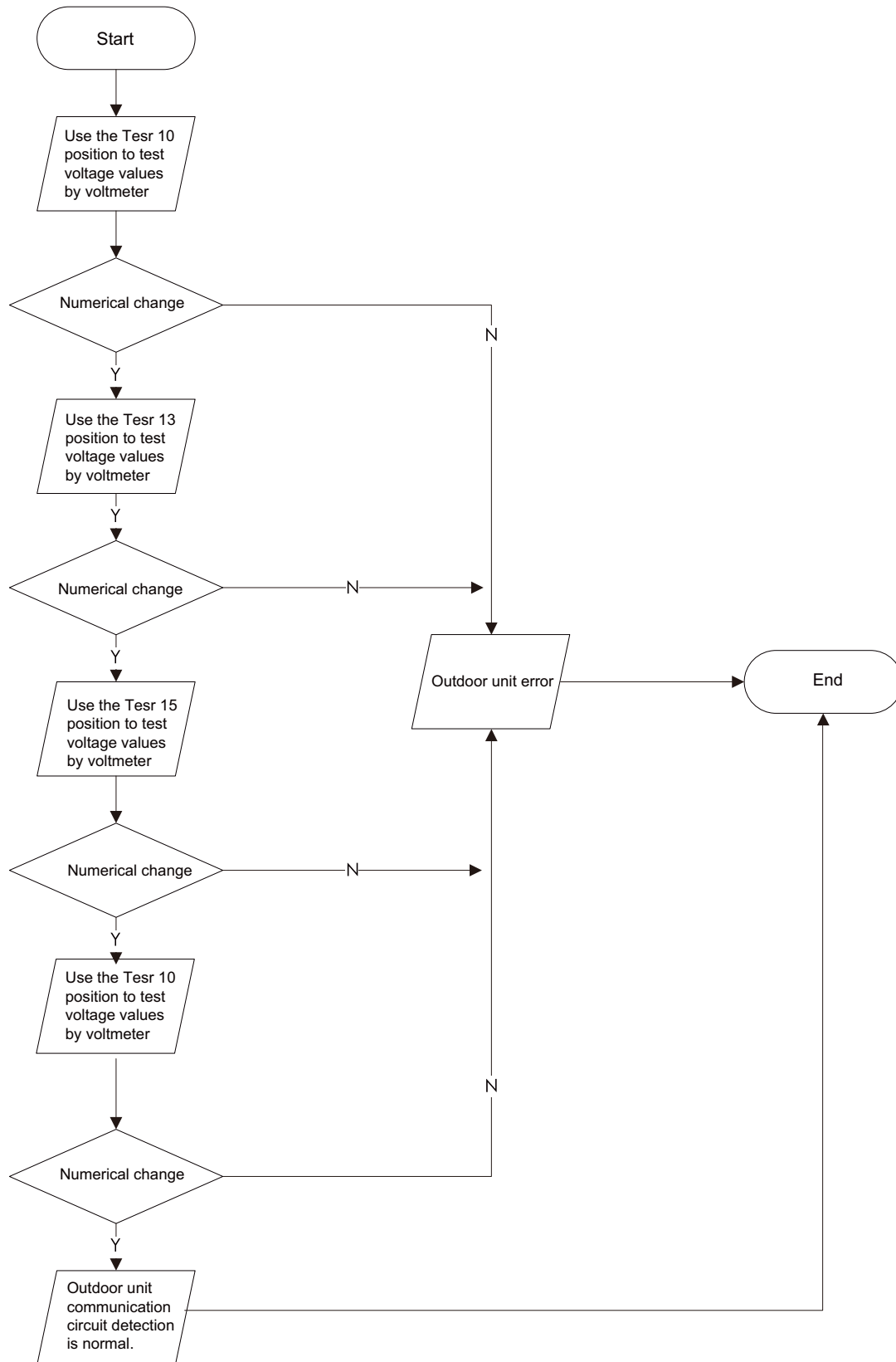

Diagram 13:

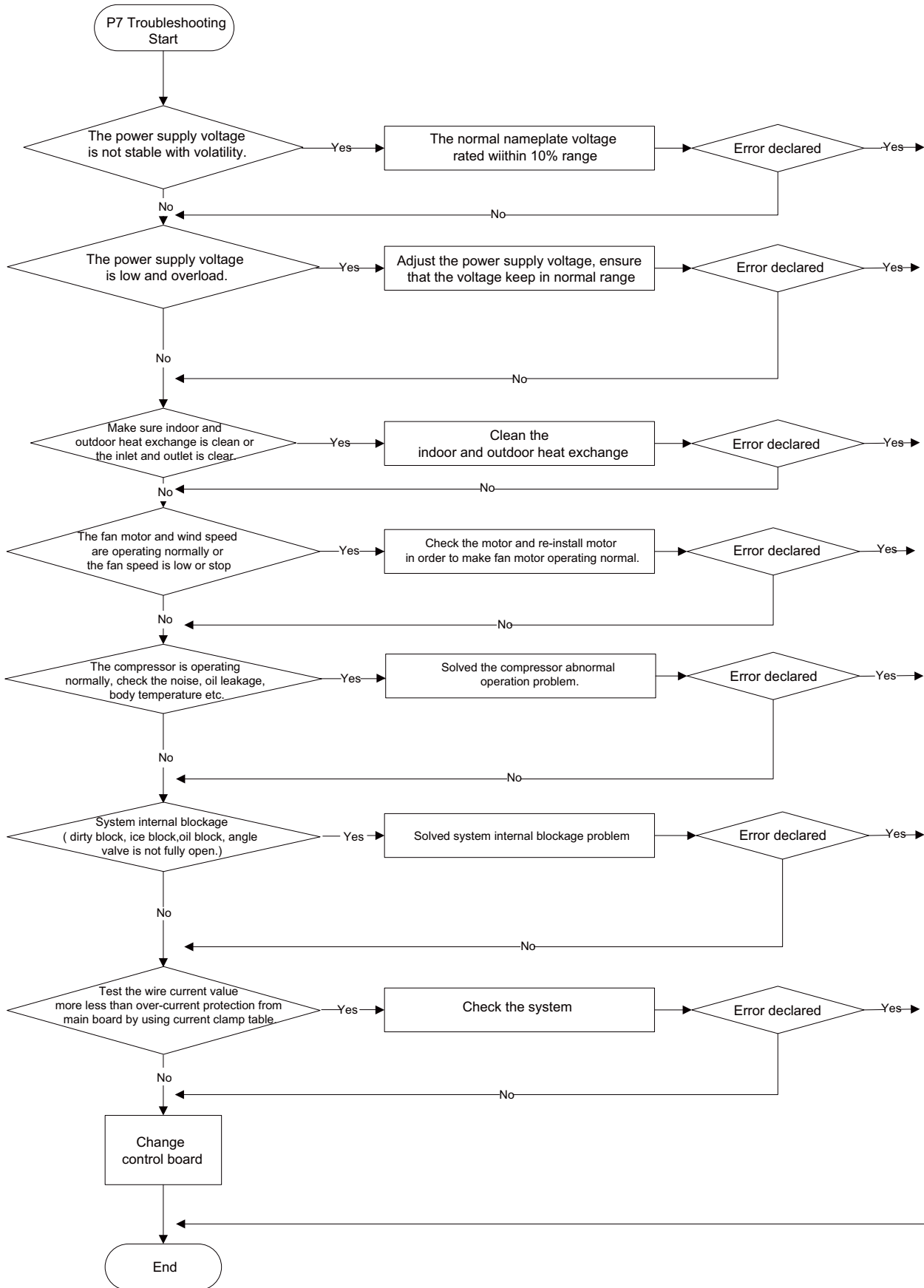
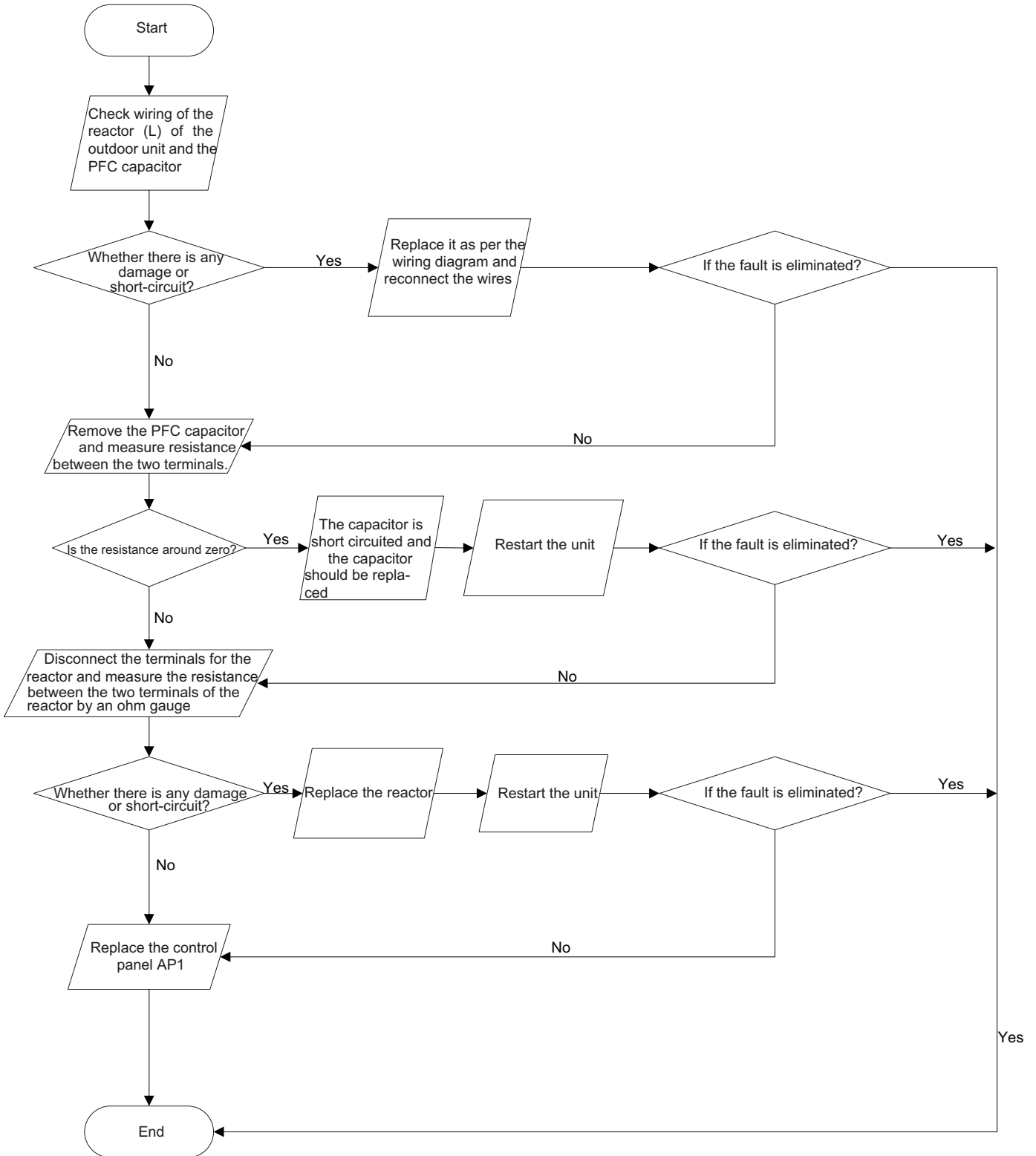

Diagram 14:

Power factor correct (PFC) fault P9 (a fault of outdoor unit) (AP1 here in after refers to the control board of the outdoor unit)
 Mainly detect:

- Check if the reactor (L) of the outdoor unit and the PFC capacitor are broken.

Fault diagnosis process:



9.4 Troubleshooting for Normal Malfunction

1. Air Conditioner Can't be Started Up

Possible Causes	Discriminating Method (Air conditioner Status)	Troubleshooting
No power supply, or poor connection for power plug	After energization, operation indicator isn't bright and the buzzer can't give out sound	Confirm whether it's due to power failure. If yes, wait for power recovery. If not, check power supply circuit and make sure the power plug is connected well.
Wrong wire connection between indoor unit and outdoor unit, or poor connection for wiring terminals	Under normal power supply circumstances, operation indicator isn't bright after energization	Check the circuit according to circuit diagram and connect wires correctly. Make sure all wiring terminals are connected firmly
Electric leakage for air conditioner	After energization, room circuit breaker trips off at once	Make sure the air conditioner is grounded reliably. Make sure wires of air conditioner is connected correctly. Check the wiring inside air conditioner. Check whether the insulation layer of power cord is damaged; if yes, place the power cord
Model selection for air switch is improper	After energization, air switch trips off	Select proper air switch
Malfunction of remote controller	After energization, operation indicator is bright, while no display on remote controller or buttons have no action	Replace batteries for remote controller Repair or replace remote controller

2. Poor Cooling (Heating) for Air Conditioner

Possible Causes	Discriminating Method (Air conditioner Status)	Troubleshooting
Set temperature is improper	Observe the set temperature on remote controller	Adjust the set temperature
Rotation speed of the IDU fan motor is set too low	Small wind blow	Set the fan speed at high or medium
Filter of indoor unit is blocked	Check the filter to see it's blocked	Clean the filter
Installation position for indoor unit and outdoor unit is improper	Check whether the installation position is proper according to installation requirement for air conditioner	Adjust the installation position, and install the rainproof and sunproof for outdoor unit
Refrigerant is leaking	Discharged air temperature during cooling is higher than normal discharged wind temperature; Discharged air temperature during heating is lower than normal discharged wind temperature; Unit's pressure is much lower than regulated range	Find out the leakage causes and deal with it. Add refrigerant.
Malfunction of 4-way valve	Blow cold wind during heating	Replace the 4-way valve
Malfunction of capillary	Discharged air temperature during cooling is higher than normal discharged wind temperature; Discharged air temperature during heating is lower than normal discharged wind temperature; Unit's pressure is much lower than regulated range. If refrigerant isn't leaking, part of capillary is blocked	Replace the capillary
Flow volume of valve is insufficient	The pressure of valves is much lower than that stated in the specification	Open the valve completely
Malfunction of horizontal louver	Horizontal louver can't swing	Refer to point 3 of maintenance method for details
Malfunction of the IDU fan motor	The IDU fan motor can't operate	Refer to troubleshooting for H6 for maintenance method in details
Malfunction of the ODU fan motor	The ODU fan motor can't operate	Refer to point 4 of maintenance method for details
Malfunction of compressor	Compressor can't operate	Refer to point 5 of maintenance method for details

3. Horizontal Louver Can't Swing

Possible Causes	Discriminating Method (Air conditioner Status)	Troubleshooting
Wrong wire connection, or poor connection	Check the wiring status according to circuit diagram	Connect wires according to wiring diagram to make sure all wiring terminals are connected firmly
Stepping motor is damaged	Stepping motor can't operate	Repair or replace stepping motor
Main board is damaged	Others are all normal, while horizontal louver can't operate	Replace the main board with the same model

4. ODU Fan Motor Can't Operate

Possible Causes	Discriminating Method (Air conditioner Status)	Troubleshooting
Wrong wire connection, or poor connection	Check the wiring status according to circuit diagram	Connect wires according to wiring diagram to make sure all wiring terminals are connected firm!
Capacity of the ODU fan motor is damaged	Measure the capacity of fan capacitor with an universal meter and find that the capacity is out of the deviation range indicated on the nameplate of fan capacitor.	Replace the capacity of fan
Power voltage is a little low or high	Use universal meter to measure the power supply voltage. The voltage is a little high or low	Suggest to equip with voltage regulator
Motor of outdoor unit is damaged	When unit is on, cooling/heating performance is bad and ODU compressor generates a lot of noise and heat.	Change compressor oil and refrigerant. If no better, replace the compressor with a new one

5. Compressor Can't Operate

Possible Causes	Discriminating Method (Air conditioner Status)	Troubleshooting
Wrong wire connection, or poor connection	Check the wiring status according to circuit diagram	Connect wires according to wiring diagram to make sure all wiring terminals are connected firm!
Capacity of compressor is damaged	Measure the capacity of fan capacitor with an universal meter and find that the capacity is out of the deviation range indicated on the nameplate of fan capacitor.	Replace the compressor capacitor
Power voltage is a little low or high	Use universal meter to measure the power supply voltage. The voltage is a little high or low	Suggest to equip with voltage regulator
Coil of compressor is burnt out	Use universal meter to measure the resistance between compressor terminals and it's 0	Repair or replace compressor
Cylinder of compressor is blocked	Compressor can't operate	Repair or replace compressor

6. Air Conditioner is Leaking

Possible Causes	Discriminating Method (Air conditioner Status)	Troubleshooting
Drain pipe is blocked	Water leaking from indoor unit	Eliminate the foreign objects inside the drain pipe
Drain pipe is broken	Water leaking from drain pipe	Replace drain pipe
Wrapping is not tight	Water leaking from the pipe connection place of indoor unit	Wrap it again and bundle it tightly

7. Abnormal Sound and Vibration

Possible Causes	Discriminating Method (Air conditioner Status)	Troubleshooting
When turn on or turn off the unit, the panel and other parts will expand and there's abnormal sound	There's the sound of "PAPA"	Normal phenomenon. Abnormal sound will disappear after a few minutes.
When turn on or turn off the unit, there's abnormal sound due to flow of refrigerant inside air conditioner	Water-running sound can be heard	Normal phenomenon. Abnormal sound will disappear after a few minutes.
Foreign objects inside the indoor unit or there're parts touching together inside the indoor unit	There's abnormal sound fro indoor unit	Remove foreign objects. Adjust all parts' position of indoor unit, tighten screws and stick damping plaster between connected parts
Foreign objects inside the outdoor unit or there're parts touching together inside the outdoor unit	There's abnormal sound fro outdoor unit	Remove foreign objects. Adjust all parts' position of outdoor unit, tighten screws and stick damping plaster between connected parts
Short circuit inside the magnetic coil	During heating, the way valve has abnormal electromagnetic sound	Replace magnetic coil
Abnormal shake of compressor	Outdoor unit gives out abnormal sound	Adjust the support foot mat of compressor, tighten the bolts
Abnormal sound inside the compressor	Abnormal sound inside the compressor	If add too much refrigerant during maintenance, please reduce refrigerant properly. Replace compressor for other circumstances.

Appendix1:Resistance Table for Indoor and Outdoor Ambient Temperature Sensors (15K)

Temp.(°C)	Resistance(kΩ)	Temp.(°C)	Resistance(kΩ)	Temp.(°C)	Resistance(kΩ)	Temp.(°C)	Resistance(kΩ)
-20	144	16	22.53	52	4.986	88	1.451
-19	138.1	17	21.51	53	4.802	89	1.408
-18	128.6	18	20.54	54	4.625	90	1.363
-17	121.6	19	19.63	55	4.456	91	1.322
-16	115	20	18.75	56	4.294	92	1.282
-15	108.7	21	17.93	57	4.139	93	1.244
-14	102.9	22	17.14	58	3.99	94	1.207
-13	97.4	23	16.39	59	3.848	95	1.171
-12	92.22	24	15.68	60	3.711	96	1.136
-11	87.35	25	15	61	3.579	97	1.103
-10	82.75	26	14.36	62	3.454	98	1.071
-9	78.43	27	13.74	63	3.333	99	1.039
-8	74.35	28	13.16	64	3.217	100	1.009
-7	70.5	29	12.6	65	3.105	101	0.9801
-6	66.88	30	12.07	66	2.998	102	0.9519
-5	63.46	31	11.57	67	2.898	103	0.9247
-4	60.23	32	11.09	68	2.797	104	0.8984
-3	57.18	33	10.63	69	2.702	105	0.873
-2	54.31	34	10.2	70	2.611	106	0.8484
-1	51.59	35	9.779	71	2.523	107	0.8246
0	49.02	36	9.382	72	2.439	108	0.8016
1	46.8	37	9.003	73	2.358	109	0.7793
2	44.31	38	8.642	74	2.28	110	0.7577
3	42.14	39	8.297	75	2.205	111	0.7369
4	40.09	40	7.967	76	2.133	112	0.7167
5	38.15	41	7.653	77	2.064	113	0.6971
6	36.32	42	7.352	78	1.997	114	0.6782
7	34.58	43	7.065	79	1.933	115	0.6599
8	32.94	44	6.791	80	1.871	116	0.6421
9	31.38	45	6.529	81	1.811	117	0.625
10	29.9	46	6.278	82	1.754	118	0.6083
11	28.51	47	6.038	83	1.699	119	0.5922
12	27.18	48	5.809	84	1.645	120	0.5765
13	25.92	49	5.589	85	1.594	121	0.5614
14	24.73	50	5.379	86	1.544	122	0.5467
15	23.6	51	5.179	87	1.497	123	0.5324

Appendix2:ResistanceTable for Indoor and Outdoor Ambient Temperature Sensors (20K)							
Temp.(°C)	Resistance(kΩ)	Temp.(°C)	Resistance(kΩ)	Temp.(°C)	Resistance(kΩ)	Temp.(°C)	Resistance(kΩ)
-30	361.8	6	48.42	42	9.803	78	2.663
-29	339.8	7	46.11	43	9.42	79	2.577
-28	319.2	8	43.92	44	9.054	80	2.495
-27	300	9	41.84	45	8.705	81	2.415
-26	282.2	10	39.87	46	8.37	82	2.339
-25	265.5	11	38.01	47	8.051	83	2.265
-24	249.9	12	36.24	48	7.745	84	2.194
-23	235.3	13	34.57	49	7.453	85	2.125
-22	221.6	14	32.98	50	7.173	86	2.059
-21	208.9	15	31.47	51	6.905	87	1.996
-20	196.9	16	30.04	52	6.648	88	1.934
-19	181.4	17	28.68	53	6.403	89	1.875
-18	171.4	18	27.39	54	6.167	90	1.818
-17	162.1	19	26.17	55	5.942	91	1.763
-16	153.3	20	25.01	56	5.726	92	1.71
-15	145	21	23.9	57	5.519	93	1.658
-14	137.2	22	22.85	58	5.32	94	1.609
-13	129.9	23	21.85	59	5.13	95	1.561
-12	123	24	20.9	60	4.948	96	1.515
-11	116.5	25	20	61	4.773	97	1.47
-10	110.3	26	19.14	62	4.605	98	1.427
-9	104.6	27	18.32	63	4.443	99	1.386
-8	99.13	28	17.55	64	4.289	100	1.346
-7	94	29	16.8	65	4.14	101	1.307
-6	89.17	30	16.1	66	3.998	102	1.269
-5	84.61	31	15.43	67	3.861	103	1.233
-4	80.31	32	14.79	68	3.729	104	1.198
-3	76.24	33	14.18	69	3.603	105	1.164
-2	72.41	34	13.59	70	3.481	106	1.131
-1	68.79	35	13.04	71	3.364	107	1.099
0	65.37	36	12.51	72	3.252	108	1.069
1	62.13	37	12	73	3.144	109	1.039
2	59.08	38	11.52	74	3.04	110	1.01
3	56.19	39	11.06	75	2.94	111	0.9825
4	53.46	40	10.62	76	2.844	112	0.9556
5	50.87	41	10.2	77	2.752	113	0.9295

Appendix 3: Resistance Table for Indoor and Outdoor Ambient Temperature Sensors (50K)

Temp. (°C)	Resistance (kΩ)	Temp. (°C)	Resistance (kΩ)	Temp. (°C)	Resistance (kΩ)	Temp. (°C)	Resistance (kΩ)	Temp. (°C)	Resistance (kΩ)
-30	911.56	6	119.08	42	24.128	78	6.542	114	2.2409
-29	853.66	7	113.37	43	23.186	79	6.3315	115	2.1816
-28	799.98	8	107.96	44	22.286	80	6.1288	116	2.1242
-27	750.18	9	102.85	45	21.425	81	5.9336	117	2.0686
-26	703.92	10	98.006	46	20.601	82	5.7457	118	2.0148
-25	660.93	11	93.42	47	19.814	83	5.5647	119	1.9626
-24	620.94	12	89.075	48	19.061	84	5.3903	120	1.9123
-23	583.72	13	84.956	49	18.34	85	5.2223	121	1.8652
-22	549.04	14	81.052	50	17.651	86	5.0605	122	1.8158
-21	516.71	15	77.349	51	16.99	87	4.9044	123	1.7698
-20	486.55	16	73.896	52	16.358	88	4.7541	124	1.7253
-19	458.4	17	70.503	53	15.753	89	4.6091	125	1.6821
-18	432.1	18	67.338	54	15.173	90	4.4693	126	1.6402
-17	407.51	19	64.333	55	14.018	91	4.3345	127	1.5996
-16	384.51	20	61.478	56	14.085	92	4.2044	128	1.5602
-15	362.99	21	58.766	57	13.575	93	4.0789	129	1.522
-14	342.83	22	56.189	58	13.086	94	3.9579	130	1.485
-13	323.94	23	53.738	59	12.617	95	3.841	131	1.449
-12	306.23	24	51.408	60	12.368	96	3.7283	132	1.4141
-11	289.61	25	49.191	61	11.736	97	3.6194	133	1.3803
-10	274.02	26	47.082	62	11.322	98	3.5143	134	1.3474
-9	259.37	27	45.074	63	10.925	99	3.4128	135	1.3155
-8	245.61	28	43.163	64	10.544	100	3.3147	136	1.2846
-7	232.67	29	41.313	65	10.178	101	3.22	137	1.2545
-6	220.5	30	39.61	66	9.8269	102	3.1285	138	1.2233
-5	209.05	31	37.958	67	9.4896	103	3.0401	139	1.1969
-4	198.27	32	36.384	68	9.1655	104	2.9547	140	1.1694
-3	188.12	33	34.883	69	8.9542	105	2.8721	141	1.1476
-2	178.65	34	33.453	70	8.5551	106	2.7922	142	1.1166
-1	169.68	35	32.088	71	8.2676	107	2.715	143	1.0913
0	161.02	36	30.787	72	7.9913	108	2.6404	144	1.0667
1	153	37	29.544	73	7.7257	109	2.5682	145	1.0429
2	145.42	38	28.359	74	7.4702	110	2.4983	146	1.0197
3	138.26	39	27.227	75	7.2245	111	2.4308	147	0.9971
4	131.5	40	26.147	76	6.9882	112	2.3654	148	0.9752
5	126.17	41	25.114	77	6.7608	113	2.3021	149	0.9538

Note: The information above is for reference only.

10. Removal Procedure

10.1 Removal Procedure of Indoor Unit

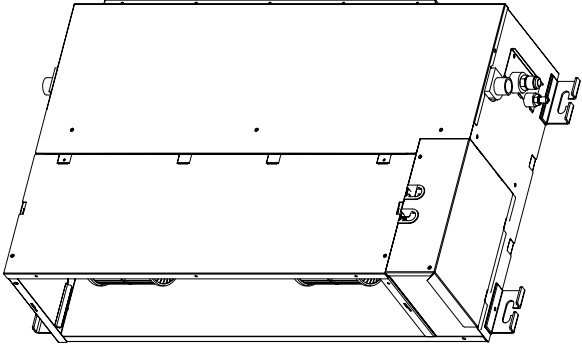
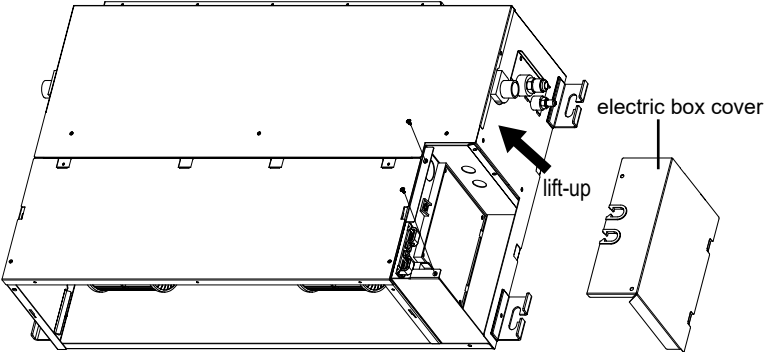
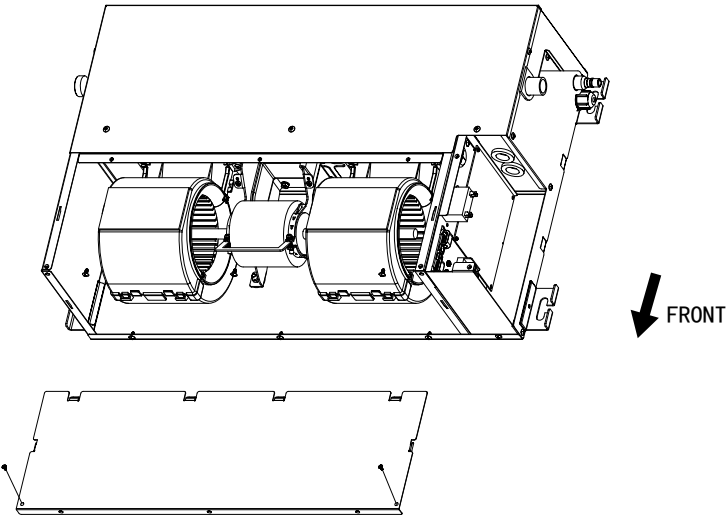

Warning Be sure to wait for a minimum of 10 minutes after turning off all power supplies before disassembly.

Procedure	Note
	<p>1. Before disassembly</p>
	<p>2. Remove electric box cover</p> <p>Remove the screws on electric box by screws-drivers and then lift-up, Loose buckles of electric box bottom and then remove the electric box cover.</p>
	<p>3. Remove lower cover plate2</p> <p>Remove the screws on electric box by screws-drivers and then lift- front, Loose buckles on two sides of lower cover plate and lift-up 45° and then remove lower cover plate2. Please refer to step 11 to remove fan motor.</p>

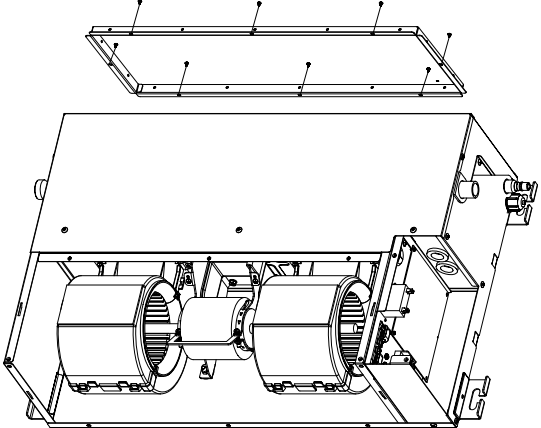
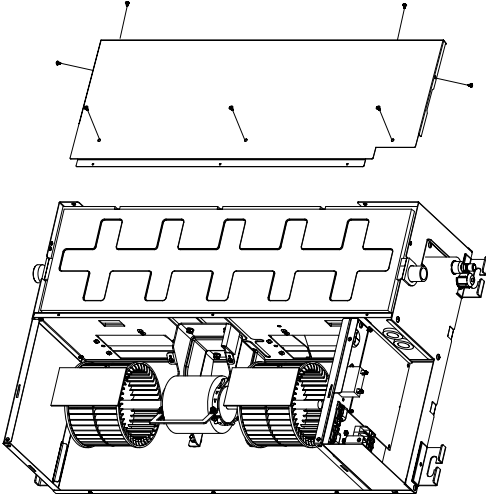
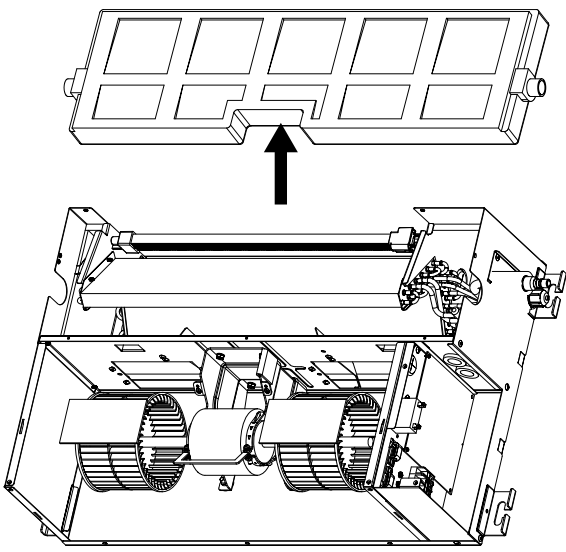
Procedure	Note
	<p>4. Remove air outlet assembly</p> <p>Loose the screws on air outlet assembly by screws-drivers and then remove air outlet assembly.</p>
	<p>5. Remove lower cover plate1</p> <p>Loose the screws on lower cover plate1 by screws-drivers and then remove lower cover plate1.</p>
	<p>6. Remove water pan</p> <p>Lift- up water pan and then remove water pan . Please refer to step 10 to remove evaporator.</p>

Procedure

Note

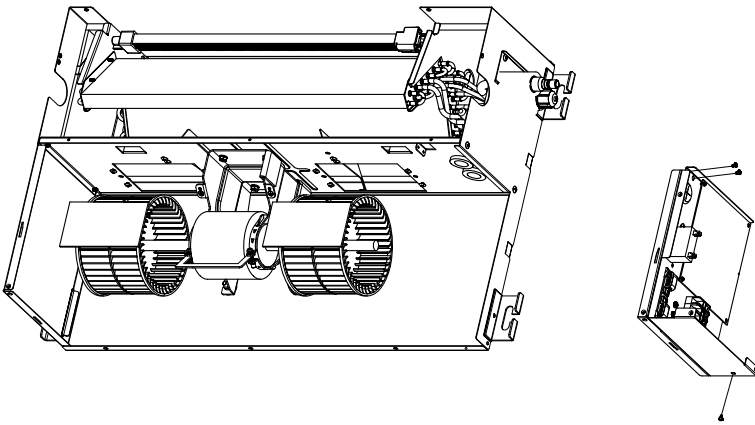

7. Remove electric box assembly

Remove the screws on electric box assembly by screws-drivers, loose the cables with all components, lift-up and then remove electric box assembly.

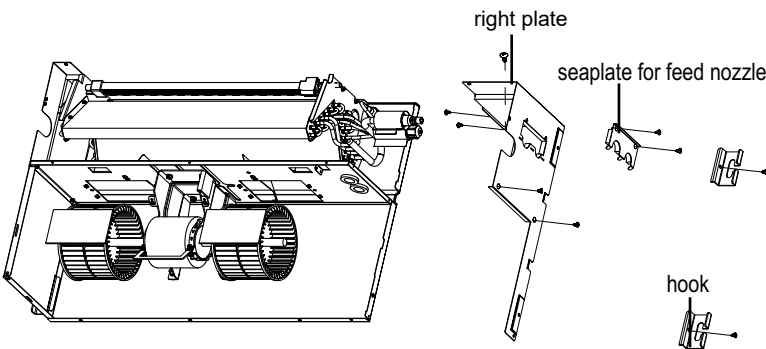

8. Remove right plate.

A: Loose the screws on seaplate for feed nozzle by screws-drivers and remove seaplate for feed nozzle.

B: Loose the screws on right plate by screws-drivers and remove right plate.

C: Remove right plate and then take down the hook.

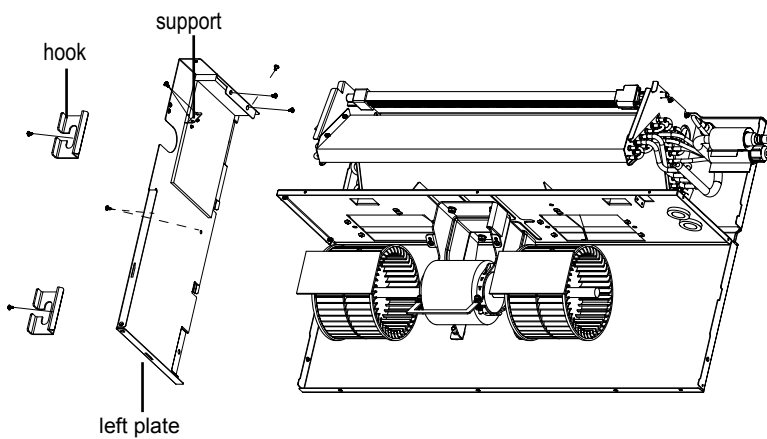

9. Remove left plate

A: Loose the fixed screws on hooks by screws-drivers.

B: Loose the fixed screws between support and evaporator by screws-drivers.

C: Loose the fixed screws on the left plate by screws-drivers and remove left plate and then take down hooks.

Procedure

Note

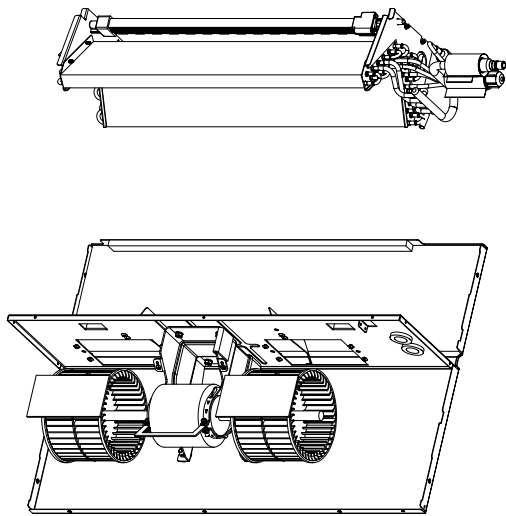

10.Remove evaporator

A: Lift-up evaporator and remove evaporator.

Note: Please check step 6 to remove evaporator, and loose the fixed screws among evaporator, left plate, right plate and sealplate, lift-up evaporator and take out liquid pipe and windpipe from right plate and then remove the evaporator assembly.

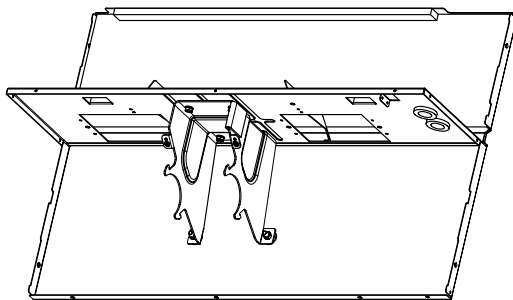

11.Remove fan motor

A:Loose the screws fixed the up propeller housing and loose the fixed motor rubber mount and then take out the centrifugal fan assembly.

B:Loose the buckles for propeller housing and then remove the up and down propeller housing.

C:Loose the fixed screws from hole on the fan motor axis and remove the centrifugation fan from fan motor axis.

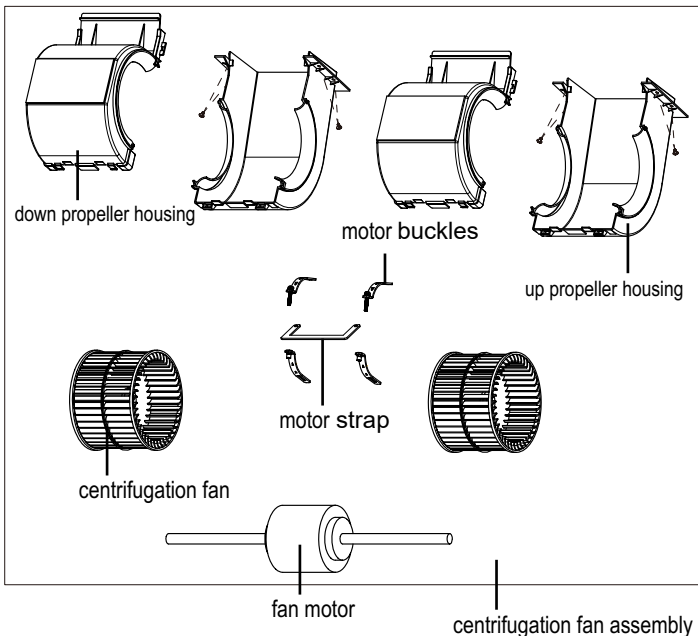

Note: remove the fan motor begin with step 11 and Loose the fixed screws from hole on the fan motor axis and remove the centrifugation fan from fan motor axis.

VEH FÁHIG I I I €

WESTERNTM
AIRCONDITIONING